

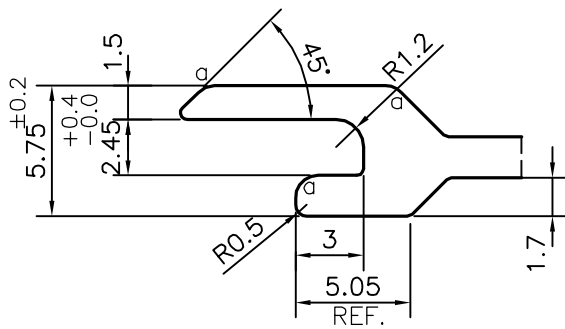

P-12450
X1652
34583

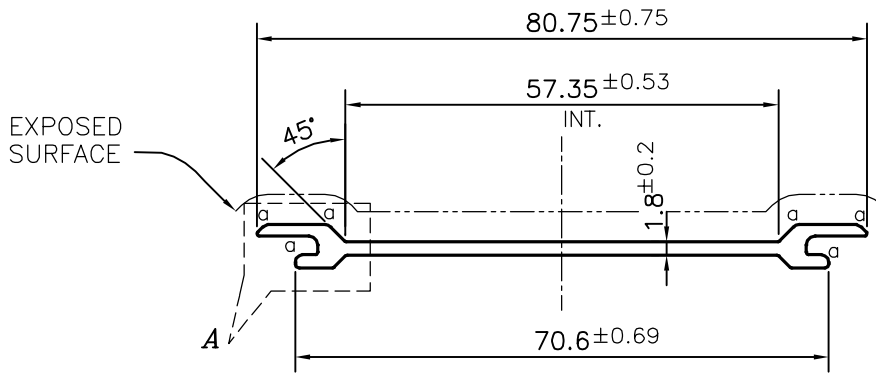
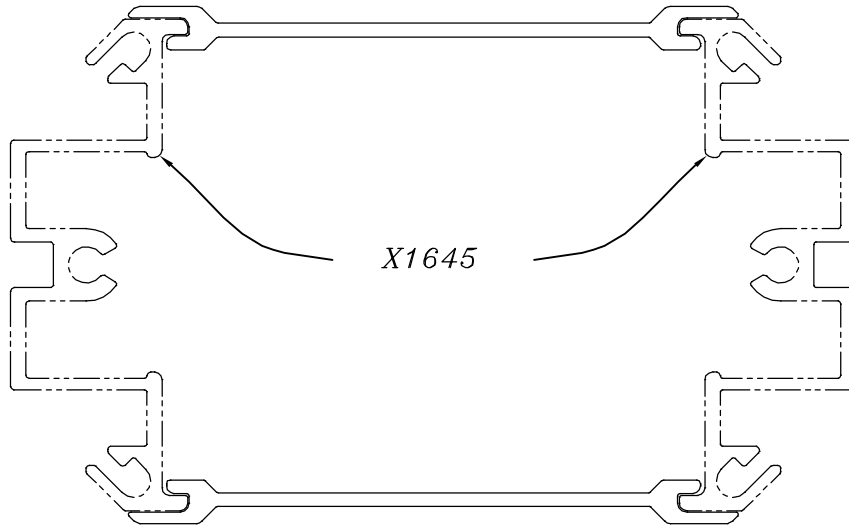

DETAIL OF "A"
SCALE 3:1

a = RADIUS 1mm. (6 PLACES)

 SYMBOL OF QUALITY AN ISO 9001 COMPANY	JINDAL ALUMINIUM LTD. BANGALORE-560073 (INDIA)	NAME		DATE
		DRAWN	PARVESH	17-01-2013
		CHECKED		
		APPROVED		S.S.GARG
		SCALE		1:1
		AREA mm ²		171.381
		PERIMETER mm.		183.904
		WEIGHT kg/m		0.463
PARTY'S NAME	FUEGO FURNITURE PVT. LTD., BANGALORE	DRAWING No.	SECTION No.	
PARTY'S DRAWING No.	SECTION No.36	P-12450	-	
ALLOY & TEMPER	HE9 WP	X1652	X1652	
		34583	34583	
DESCRIPTION	FURNITURE SECTION			