

P-12589

S3712

34586

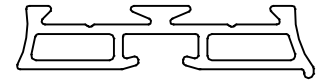
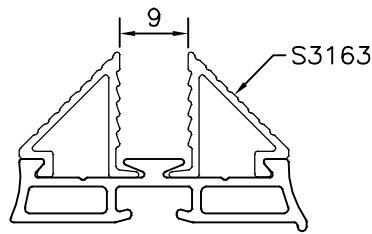

SCALE :- 1:1

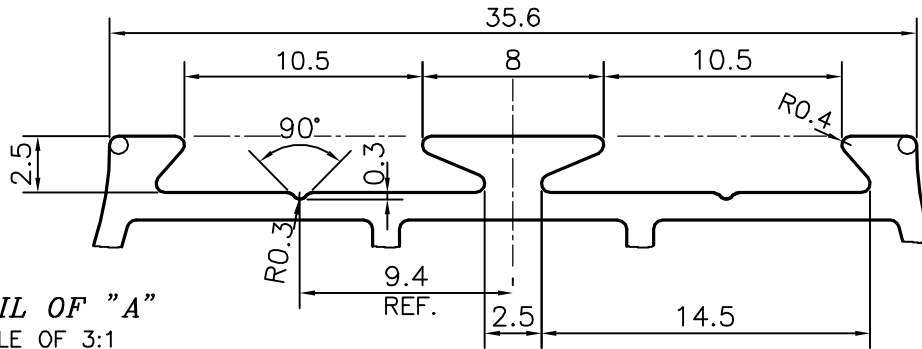

DETAIL OF "A"
SCALE OF 3:1

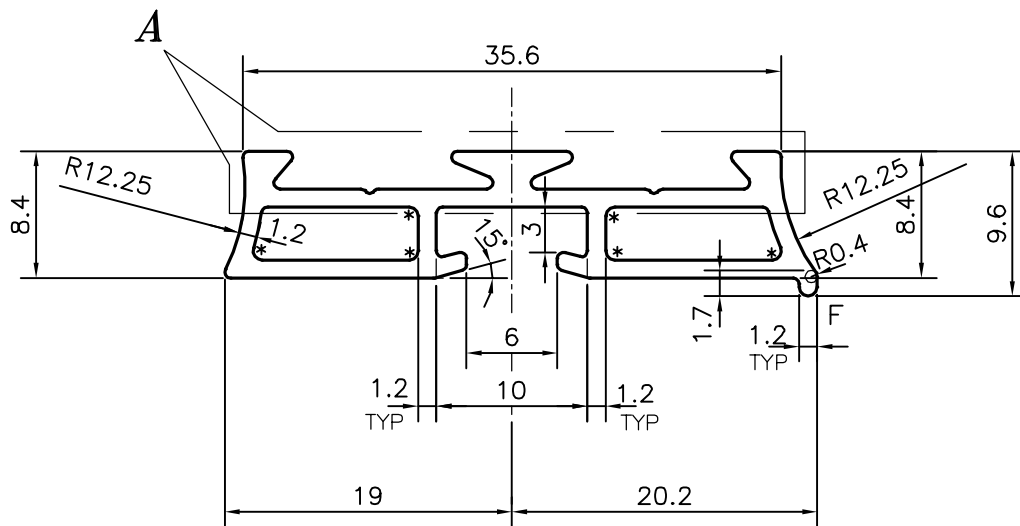

x = RADIUS 0.6 mm. (6 PLACES)
F = FULL RADIUS



SYMBOL OF QUALITY
AN ISO 9001 COMPANY

JINDAL ALUMINIUM LTD.
BANGALORE-560073 (INDIA)

	NAME	DATE
DRAWN	J.P.KAUSHIK	07-03-2013
CHECKED		
APPROVED	S.S.GARG	09-04-2013
SCALE		2:1
AREA mm ²		127.608
PERIMETER mm.		130.665
WEIGHT kg/m		0.345
DRAWING No.	SECTION No.	
P-12589	-	
S3712	S3712	
34586	34586	

1. ALL DIMENSIONS ARE IN mm.
2. ROUND OFF ALL SHARP CORNERS WITH 0.40 mm.
3. TOLERANCES WILL BE AS PER IS:6477-1983, UNLESS OTHERWISE SPECIFIED

PARTY'S NAME	ZEN MODULAR SYSTEMS (I) PVT. LTD., (COIMBATORE)
PARTY'S DRAWING No.	ZEN/DOOR/002
ALLOY & TEMPER	63400 WP
DESCRIPTION	FURNITURE SECTION