

P-12657
S3738
34587

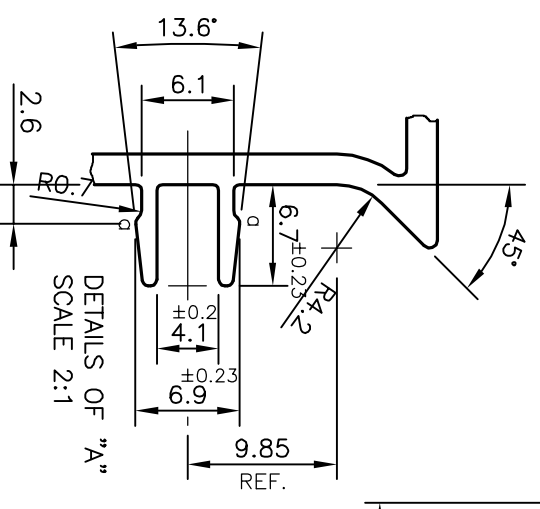
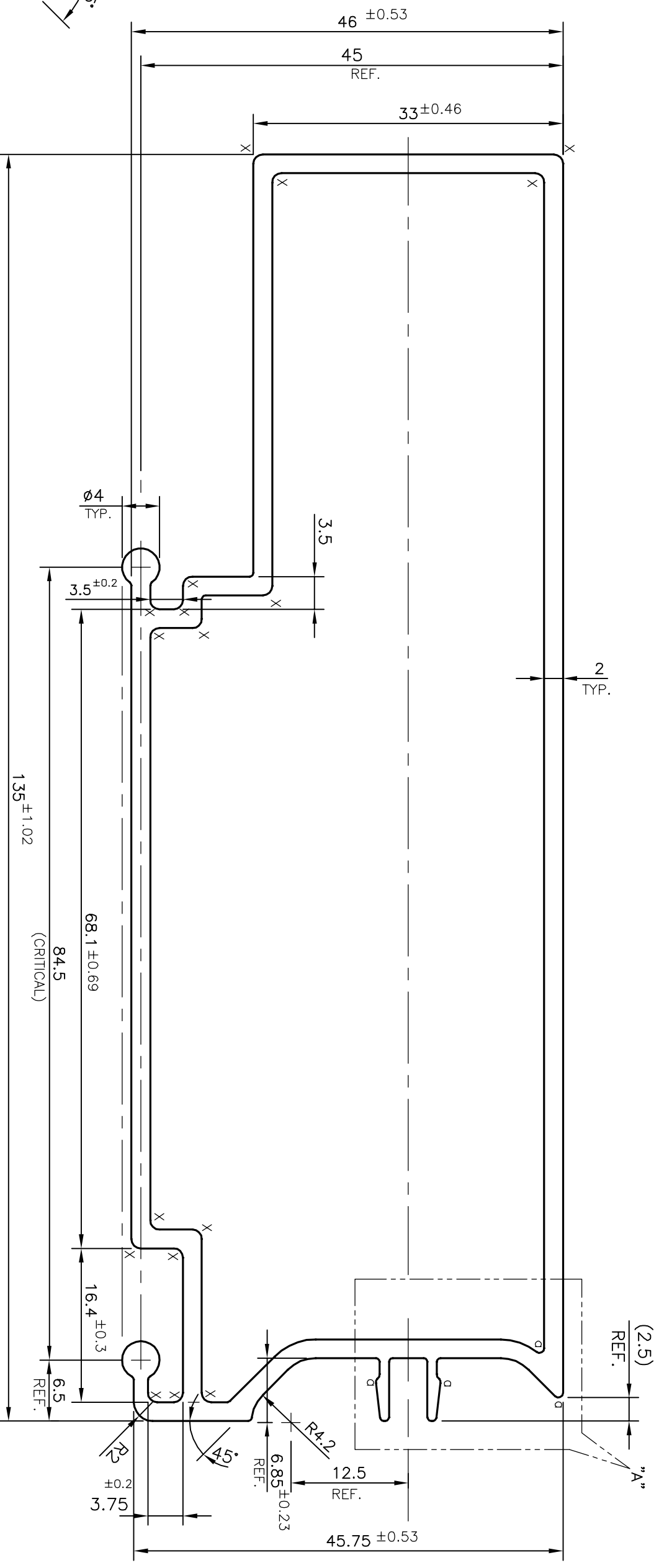

d = RADIUS 0.5 mm. (4 PLACES)
X = RADIUS 1 mm. (17 PLACES)

TOLERANCES ON OVERALL WIDTHS & WIDTHS ACROSS FLATS OF BARS, & REGULAR SECTIONS

UPTO 6.40mm - ±0.20	UPTO 32.0mm - ±0.38	UPTO 120.0mm - ±0.85	UPTO 320.00mm - ±1.70
UPTO 10.0mm - ±0.23	UPTO 50.0mm - ±0.46	UPTO 160.0mm - ±1.02	
UPTO 12.0mm - ±0.25	UPTO 60.0mm - ±0.53	UPTO 200.0mm - ±1.14	
UPTO 16.0mm - ±0.28	UPTO 80.0mm - ±0.69	UPTO 250.0mm - ±1.40	
UPTO 25.0mm - ±0.30	UPTO 100.0mm - ±0.75	UPTO 300.0mm - ±1.65	

JINDAL
SYMBOL OF QUALITY
AN ISO 9001 COMPANY
JINDAL ALUMINIUM LTD.
BANGALORE-560073 (INDIA)

1. ALL DIMENSIONS ARE IN mm.
2. ROUND OFF ALL SHARP CORNERS WITH 0.40 mm.
3. TOLERANCES WILL BE AS PER IS:6477-1983 UNLESS OTHERWISE SPECIFIED

PARTY'S NAME	FUEGO FURNITURE PVT. LTD., BANGALORE	SCALE	2:1
PARTY'S DRAWING No.	SECTION No.76	AREA mm ²	770.294
ALLOY & TEMPER	HE9 WP	PERIMETER mm.	423.913
DESCRIPTION	FURNITURE SECTION	WEIGHT kg/m	2.08
		DRAWING No.	SECTION No.
		P-12657	-
		S3738	S3738
		34587	34587

