

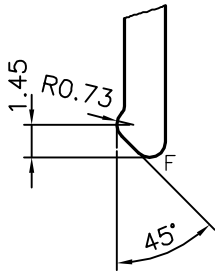

P-14517
X1886
34592

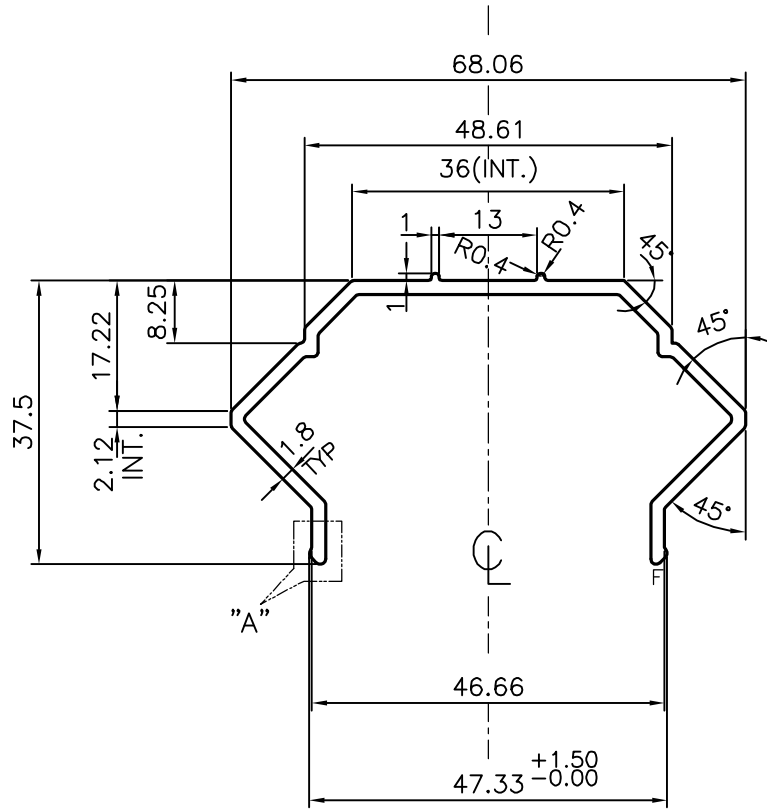

DETAILS OF "A"
SCALE 3:1

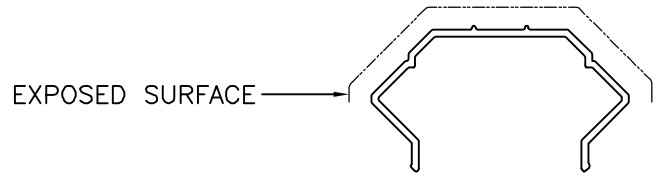
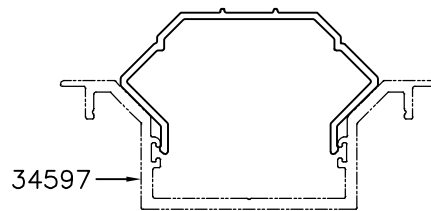

F = FULL RADIUS (6 PLACES)

 SYMBOL OF QUALITY AN ISO 9001 COMPANY	JINDAL ALUMINIUM LTD. BANGALORE-560073 (INDIA)	NAME	DATE
		DRAWN	J.P.KAUSHIK
1. ALL DIMENSIONS ARE IN mm. 2. ROUND OFF ALL SHARP CORNERS WITH 0.40 mm. 3. TOLERANCES WILL BE AS PER BS:EN-755-9 UNLESS OTHERWISE SPECIFIED		CHECKED	
		APPROVED	S.S.GARG
PARTY'S NAME ERGO CREATIVE SOLUTIONS PVT. LTD., BANGALORE		SCALE	1:1
		AREA mm ²	238.643
PARTY'S DRAWING No. 01070000047		PERIMETER mm.	267.207
		WEIGHT kg/m	0.644
ALLOY & TEMPER 6063 T6		DRAWING No.	SECTION No.
		P-14517	-
DESCRIPTION MISC. SECTION		X1886	X1886
		34592	34592