

P-14567

X1891

34597

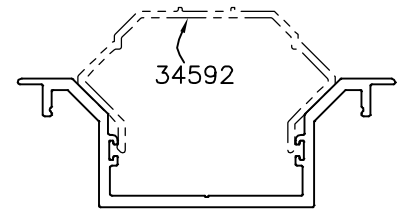

SCALE :- 0.5:1

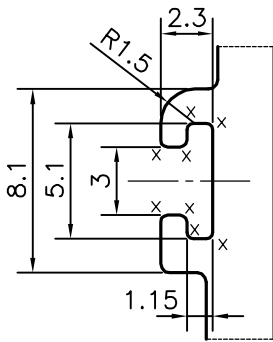
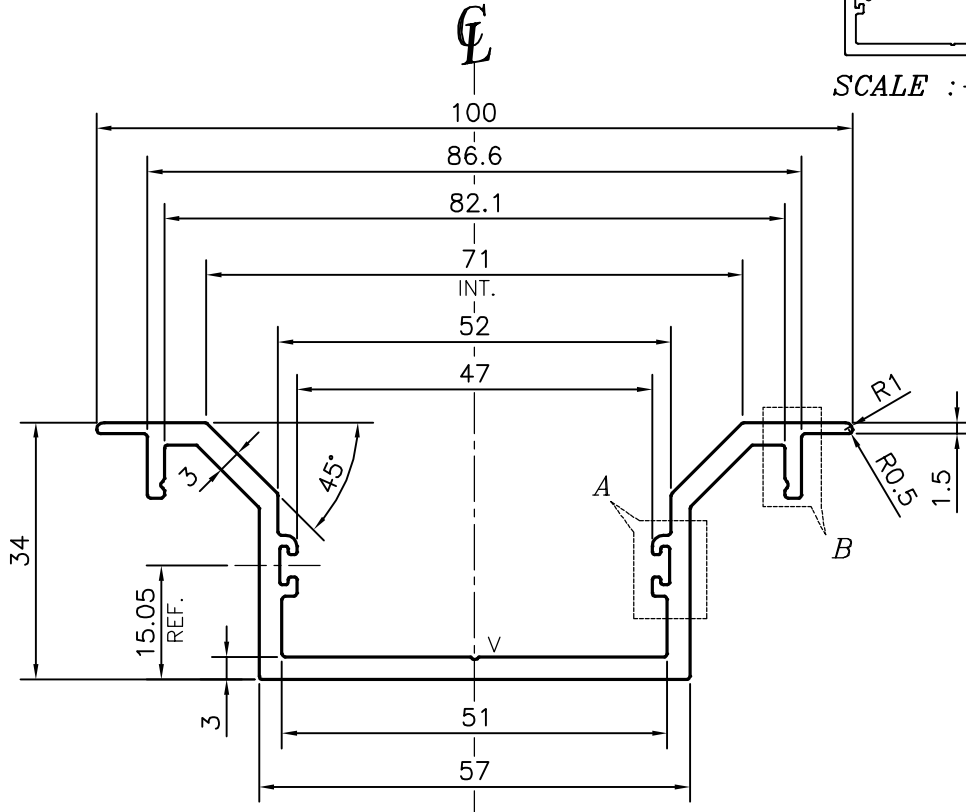

DETAIL OF "A"  
SCALE 3:1

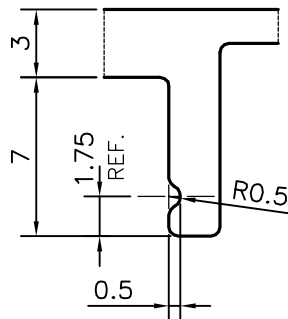

DETAIL OF "A"  
SCALE 3:1

X = RADIUS 0.3 mm. (16 PLACE)  
V = VEE GROOVE 0.4x90° (1 PLACE)

TOLERANCES ON OVERALL WIDTHS & WIDTHS ACROSS FLATS OF BARS, & REGULAR SECTIONS

UPTO 6.40mm - ±0.20	UPTO 32.0mm - ±0.38	UPTO 120.0mm - ±0.85	1. STRAIGHTNESS=1.7mm/M 2. TWIST=1.7mm/M 3. ANGULARITY= ±2° 4. FLATNESS =0.007xWIDTH
UPTO 10.0mm - ±0.23	UPTO 50.0mm - ±0.46	UPTO 160.0mm - ±1.02	
UPTO 12.0mm - ±0.25	UPTO 60.0mm - ±0.53	UPTO 200.0mm - ±1.14	
UPTO 16.0mm - ±0.28	UPTO 80.0mm - ±0.69	UPTO 250.0mm - ±1.40	
UPTO 25.0mm - ±0.30	UPTO 100.0mm - ±0.75	UPTO 300.0mm - ±1.65	



SYMBOL OF QUALITY  
AN ISO 9001 COMPANY

**JINDAL ALUMINIUM LTD.**  
BANGALORE-560073 (INDIA)

	NAME	DATE
DRAWN	PARVESH	21-04-2015
CHECKED		
APPROVED	S.S.GARG	12-06-2015

1. ALL DIMENSIONS ARE IN mm.
2. ROUND OFF ALL SHARP CORNERS WITH 0.40 mm.
3. TOLERANCES WILL BE AS PER IS:3965-1981 , UNLESS OTHERWISE SPECIFIED

SCALE	1:1
AREA mm <sup>2</sup>	471.39
PERIMETER mm.	356.053
WEIGHT kg/m	1.273

PARTY'S NAME	ERGO CREATIVE SOLUTIONS PVT. LTD., BANGALORE
PARTY'S DRAWING No.	AS PER AUTOCAD DRAWING-01070000040
ALLOY & TEMPER	6063 T6
DESCRIPTION	FURNITURE SECTION

DRAWING No.	SECTION No.
P-14567	-
X1891	X1891
34597	34597