

P-13895-1

S4284

34606

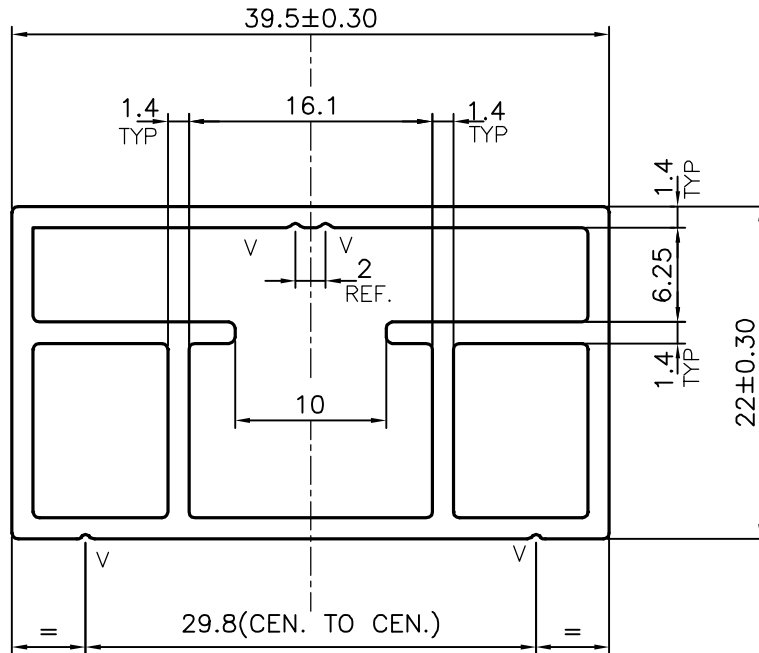
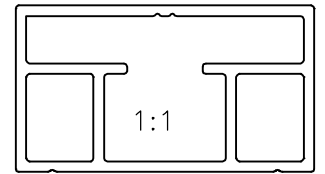

V = V GROOVE 0.3x90°(4 PLACES)



SYMBOL OF QUALITY  
AN ISO 9001 COMPANY

**JINDAL ALUMINIUM LTD.**  
BANGALORE-560073 (INDIA)

	NAME	DATE
DRAWN	J.P.KAUSHIK	08-10-2014
CHECKED		
APPROVED	S.S.CARG	05-11-2014

1. ALL DIMENSIONS ARE IN mm.
2. ROUND OFF ALL SHARP CORNERS WITH 0.40 mm.
3. TOLERANCES WILL BE AS PER IS:6477-1983, UNLESS OTHERWISE SPECIFIED

SCALE	2:1
AREA mm <sup>2</sup>	233.65
PERIMETER mm.	122.69
WEIGHT kg/m	0.631

PARTY'S NAME	LORD GEM, NEW DELHI	DRAWING No.	P-13895-1	SECTION No.	-
PARTY'S DRAWING No.	AS PER SAMPLE		S4284		S4284
ALLOY & TEMPER	HE9 WP		34606		34606
DESCRIPTION	MISC. SECTION				