

P-15114

S4631

34617

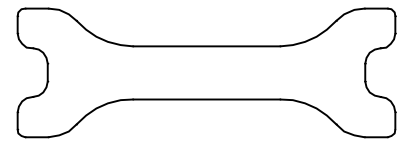

1:1

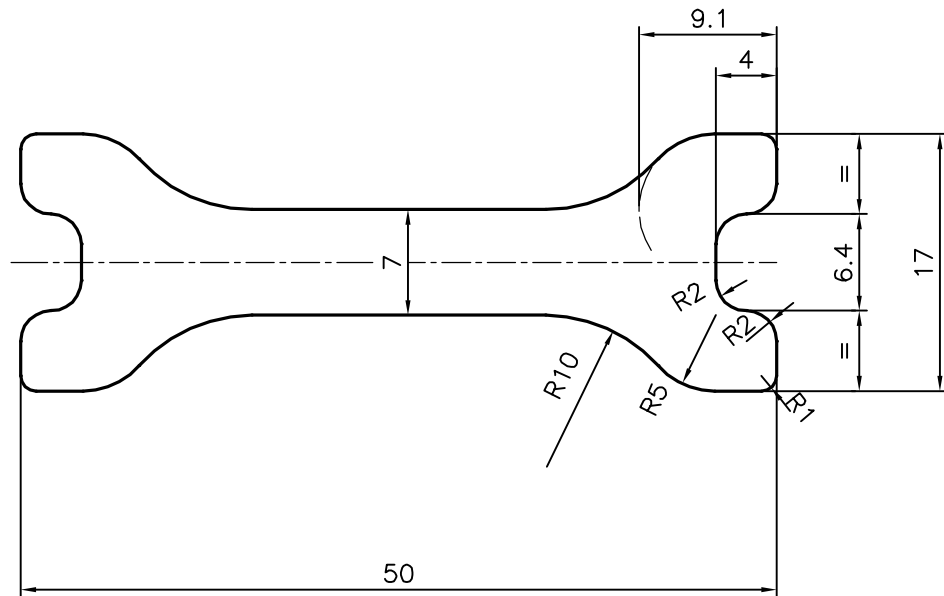

SYMBOL OF QUALITY
AN ISO 9001 COMPANY

JINDAL ALUMINIUM LTD.
BANGALORE-560073 (INDIA)

	NAME	DATE
DRAWN	J.P.KAUSHIK	01-09-2015
CHECKED		
APPROVED	S.S.GARG	04-09-2015
SCALE		2:1
AREA mm ²		477.388
PERIMETER mm.		147.159
WEIGHT kg/m		1.289
DRAWING No.	SECTION No.	
P-15114	-	
S4631	S4631	
34617	34617	

1. ALL DIMENSIONS ARE IN mm.
2. ROUND OFF ALL SHARP CORNERS WITH 0.40 mm.
3. TOLERANCES WILL BE AS PER IS:3965-1981, UNLESS OTHERWISE SPECIFIED

PARTY'S NAME	M.R ALUMINIUM, BANGALORE
PARTY'S DRAWING No.	AS PER AutoCAD
ALLOY & TEMPER	6063 T6
DESCRIPTION	MISC. SECTION