

P-14824

S4524

34618

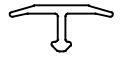

1:1

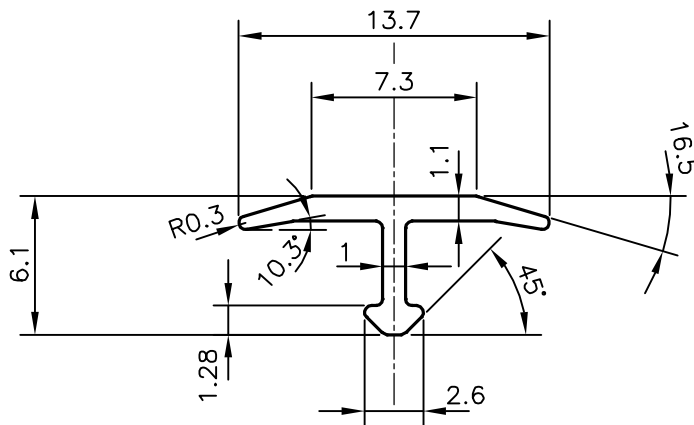
**ISSUE-2**

SHAPE & SIZE CHANGED

WEIGHT ALSO CHANGED FROM 0.071 kg/m TO 0.052 kg/m

UNSPECIFIED RADIUS 0.30 mm



SYMBOL OF QUALITY
AN ISO 9001 COMPANY

JINDAL ALUMINIUM LTD.
BANGALORE-560073 (INDIA)

	NAME	DATE
DRAWN	J.P.KAUSHIK	18-09-2015
CHECKED		
APPROVED	S.S.GARG	22-09-2015
SCALE		3:1
AREA mm ²		19.33
PERIMETER mm.		39.777
WEIGHT kg/m		0.052
DRAWING No.		SECTION No.
P-14824		-
S4524		S4524(ISSUE-2)
34618		34618

1. ALL DIMENSIONS ARE IN mm.
2. ROUND OFF ALL SHARP CORNERS WITH 0.40 mm.
3. TOLERANCES WILL BE AS PER IS:3965-1981 , UNLESS OTHERWISE SPECIFIED

PARTY'S NAME	FALANX FLOOR SOLUTIONS PVT. LTD., BANGALORE
PARTY'S DRAWING No.	AS PER SAMPLE
ALLOY & TEMPER	6063 T6
DESCRIPTION	T SECTION-MISC.