

P-14886

S4542

34619



1:1

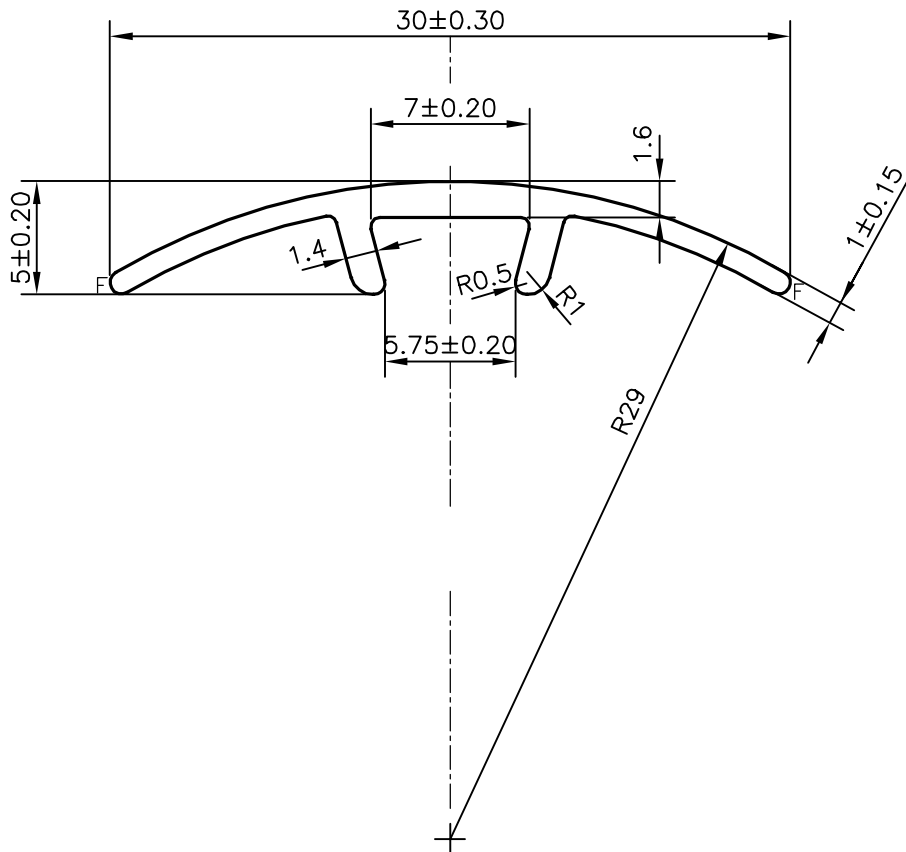

F = FULL RADIUS (2 PLACES)



SYMBOL OF QUALITY
AN ISO 9001 COMPANY

JINDAL ALUMINIUM LTD.
BANGALORE-560073 (INDIA)

	NAME	DATE
DRAWN	J.P.KAUSHIK	16-07-2015
CHECKED		
APPROVED	B.NATARAJA	23-07-2015
SCALE		3:1
AREA mm ²		45.341
PERIMETER mm.		76.068
WEIGHT kg/m		0.122
DRAWING No.	SECTION No.	
P-14886	-	
S4542	S4542	
34619	34619	

1. ALL DIMENSIONS ARE IN mm.
2. ROUND OFF ALL SHARP CORNERS WITH 0.40 mm.
3. TOLERANCES WILL BE AS PER IS:3965-1981 , UNLESS OTHERWISE SPECIFIED

PARTY'S NAME	FALANX FLOOR SOLUTIONS PVT. LTD., BANGALORE
PARTY'S DRAWING No.	FAACFT30
ALLOY & TEMPER	HE9 WP
DESCRIPTION	MODULAR FURNITURE SECTION