

P-18158

X2349

34636

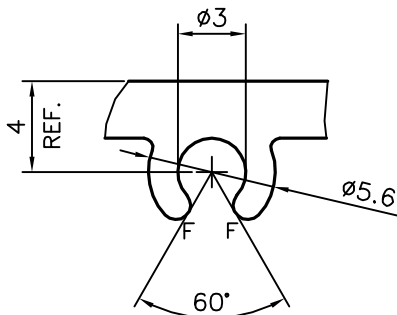
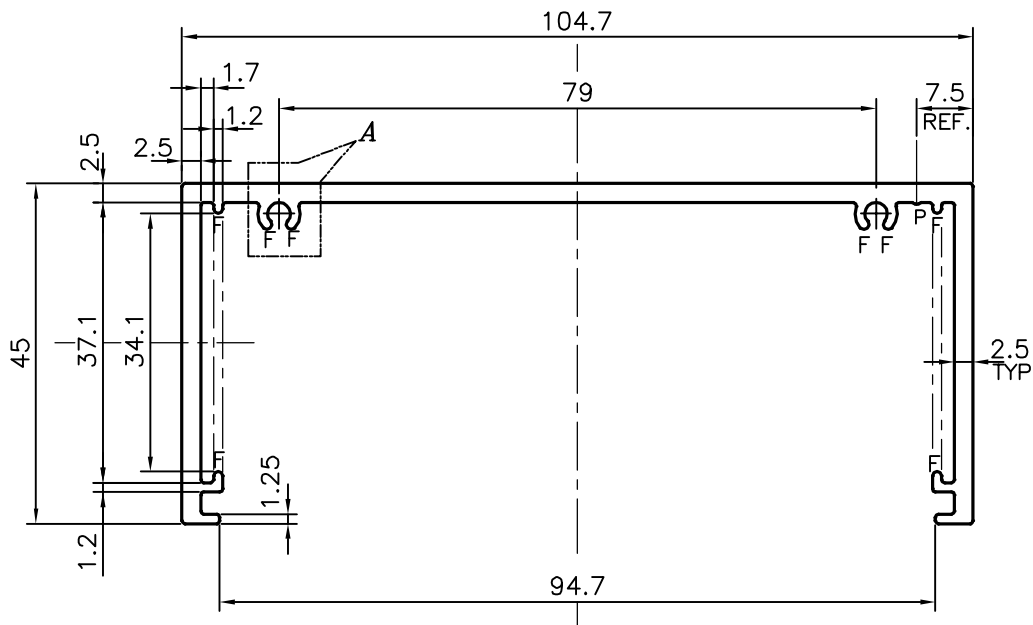
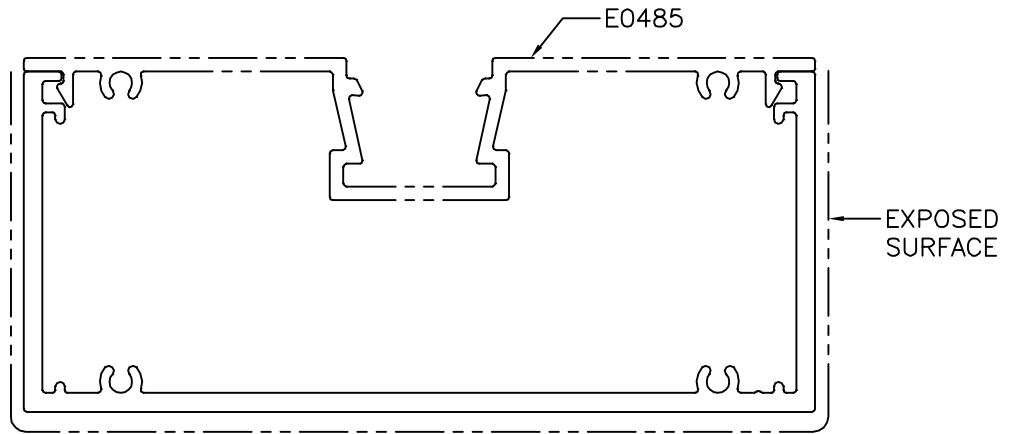

DETAIL OF "A"
SCALE 3:1

P = PIP 0.3
F = FULL RADIUS (8 PLACES)



SYMBOL OF QUALITY
AN ISO 9002 COMPANY

JINDAL ALUMINIUM LTD.
BANGALORE-560073 (INDIA)

	NAME	DATE
DRAWN	J.P.KAUSHIK	27-04-2018
CHECKED		
APPROVED	B.NATARAJA	15-06-2018
SCALE		1:1
AREA mm ²		514.508
PERIMETER mm.		437.325
WEIGHT kg/m		1.389
DRAWING No.	SECTION No.	
P-18158	-	
X2349	X2349	
34636	34636	

1. ALL DIMENSIONS ARE IN mm.
2. ROUND OFF ALL SHARP CORNERS WITH 0.40 mm.
3. TOLERANCES WILL BE AS PER IS:3965-1981 UNLESS OTHERWISE SPECIFIED

PARTY'S NAME	H.V.ART N GLASS PVT. LTD., DELHI
PARTY'S DRAWING No.	MODIFIED OF E0484
ALLOY & TEMPER	6063 T6
DESCRIPTION	MISC. SECTION