

P-21860

34637

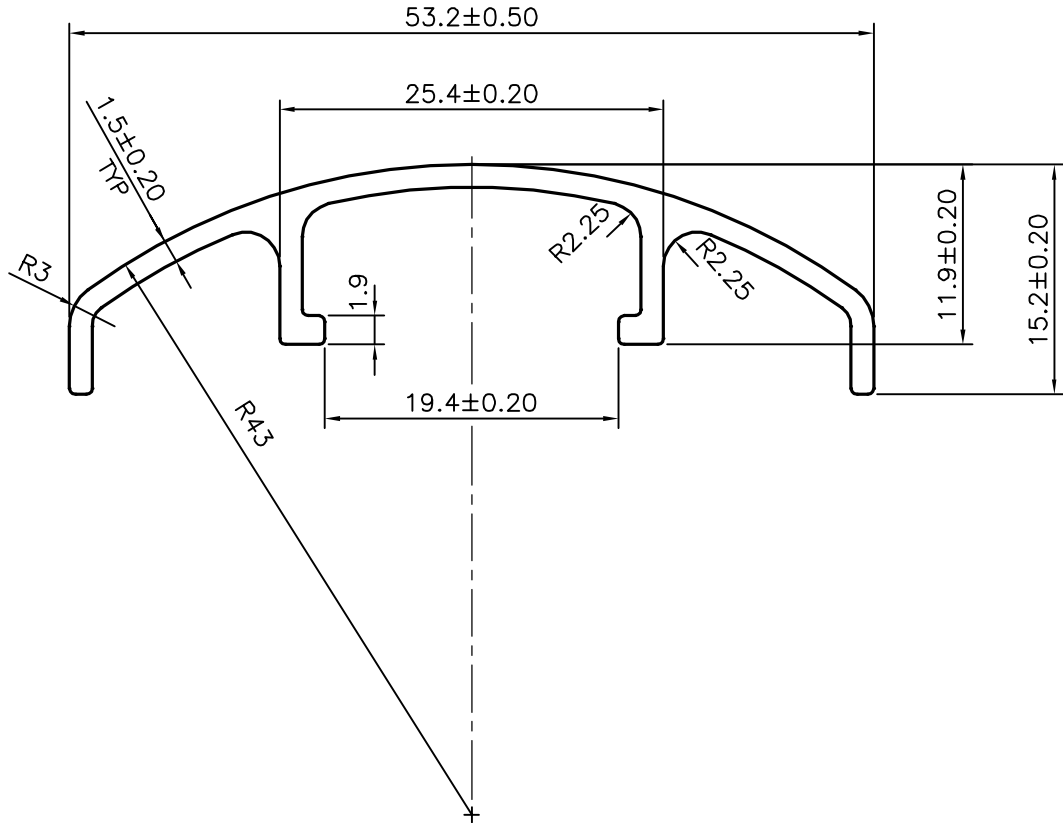

APPROXIMATE WEIGHT RANGE - 0.321 - 0.420 kg/m

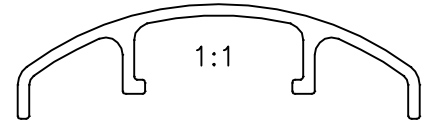

SYMBOL OF QUALITY  
AN ISO 9001 COMPANY

**JINDAL ALUMINIUM LTD.**  
BANGALORE-560073 (INDIA)

|                      | NAME        | DATE       |
|----------------------|-------------|------------|
| DRAWN                | J.P.KAUSHIK | 14-12-2020 |
| CHECKED              |             |            |
| APPROVED             | B.NATARAJA  | 17-12-2020 |
| SCALE                |             | 2:1        |
| AREA mm <sup>2</sup> |             | 137.25     |
| PERIMETER mm.        |             | 169.167    |
| WEIGHT kg/m          |             | 0.371      |
| DRAWING No.          | SECTION No. |            |
| P-21860              | -           |            |
| 34637                | 34637       |            |
|                      |             |            |
|                      |             |            |

1. ALL DIMENSIONS ARE IN mm.
2. ROUND OFF ALL SHARP CORNERS WITH 0.40 mm.
3. TOLERANCES WILL BE AS PER IS:3965-1981 UNLESS OTHERWISE SPECIFIED

|                     |                   |
|---------------------|-------------------|
| PARTY'S NAME        | SPACES, BANGALORE |
| PARTY'S DRAWING No. | AS PER SAMPLE     |
| ALLOY & TEMPER      | 6063 T6           |
| DESCRIPTION         | FURNITURE SECTION |