

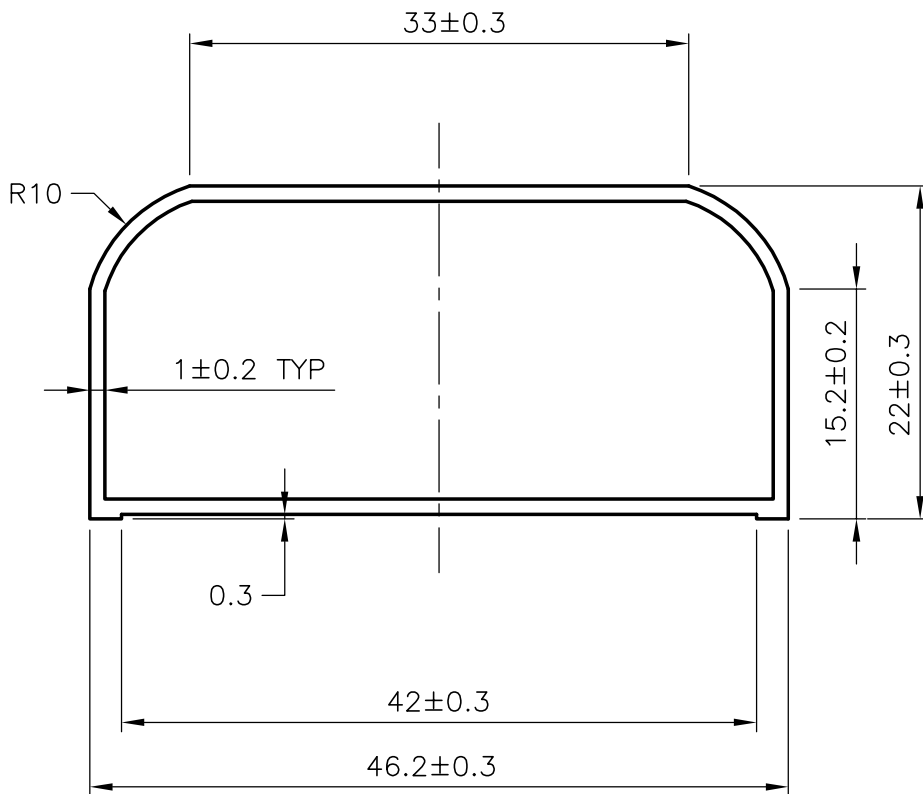

X154  
X171  
35009

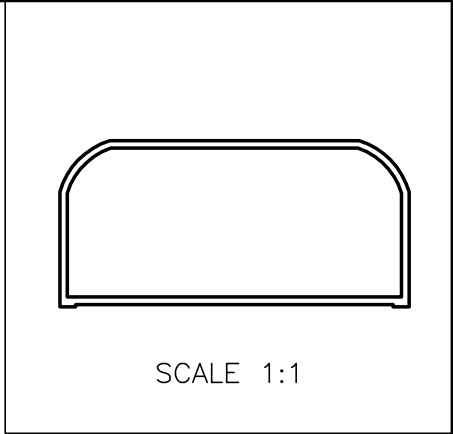

 SYMBOL OF QUALITY AN ISO 9002 COMPANY	<b>JINDAL ALUMINIUM LTD.</b> BANGALORE-560073 (INDIA)		NAME	DATE
		DRAWN	RANGASWAMY	08-03-01
		CHECKED		
1. ALL DIMENSIONS ARE IN mm. 2. ROUND OFF ALL SHARP CORNERS WITH 0.40 mm. 3. TOLERANCES WILL BE AS PER IS:6477-1983 UNLESS OTHERWISE SPECIFIED		APPROVED		
		SCALE	2:1 & 1:1	
		WEIGHT kg/m	0.341	
PARTY'S NAME	COMPLETE SURVEYING TECHNOLOGIES(p) LTD .,NOIDA	SECTION No.	35009	
PARTY'S DRAWING No.	AS PER DRAWING (B-8573) (SECTION NO.2)	DRAWING No.	35009	
ALLOY & TEMPER	HE9 WP			
DESCRIPTION	-			