

PERIMETER =99.27mm

P-3389

X173

35011



SCALE 1:1

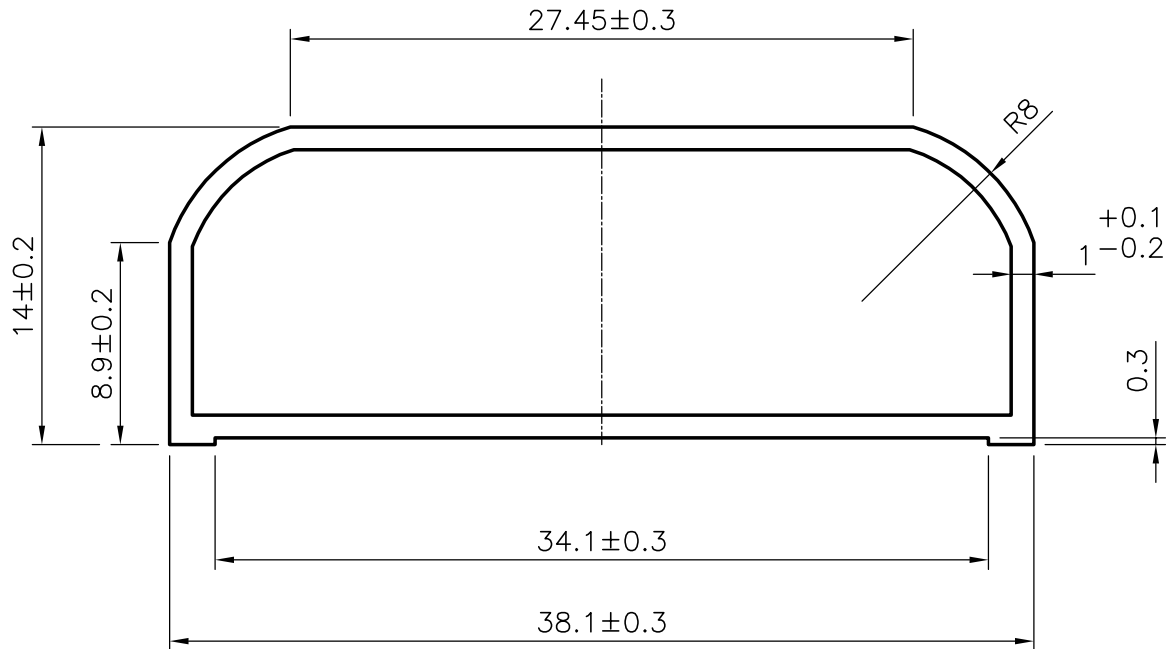

GENERAL WALL THICKNESS = 1mm

PLEASE SPECIFY THE EXPOSED SURFACE IN THE DRAWING WHEREVER BETTER FINISH REQUIRED

 SYMBOL OF QUALITY AN ISO 9002 COMPANY	JINDAL ALUMINIUM LTD. BANGALORE-560073 (INDIA)		NAME	DATE
		DRAWN	RAGHAVENDRA	23-06-01
1. ALL DIMENSIONS ARE IN mm. 2. ROUND OFF ALL SHARP CORNERS WITH 0.40 mm. 3. TOLERANCES WILL BE AS PER I.S 6477-1983 UNLESS OTHERWISE SPECIFIED		CHECKED		
		APPROVED		
PARTY'S NAME	COMPLETE SURVEYING TECHNOLOGIES(P) LTD, NOIDA	SCALE	3:1 & 1:1	
PARTY'S DRAWING No.	AS PER DRAWING	WEIGHT kg/m	0.258	
ALLOY & TEMPER	HE9 WP	SECTION No.	35011	
DESCRIPTION	-	DRAWING No.	35011	