

P-7417-2

X710

35016

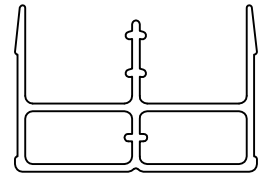

SCALE 1:1

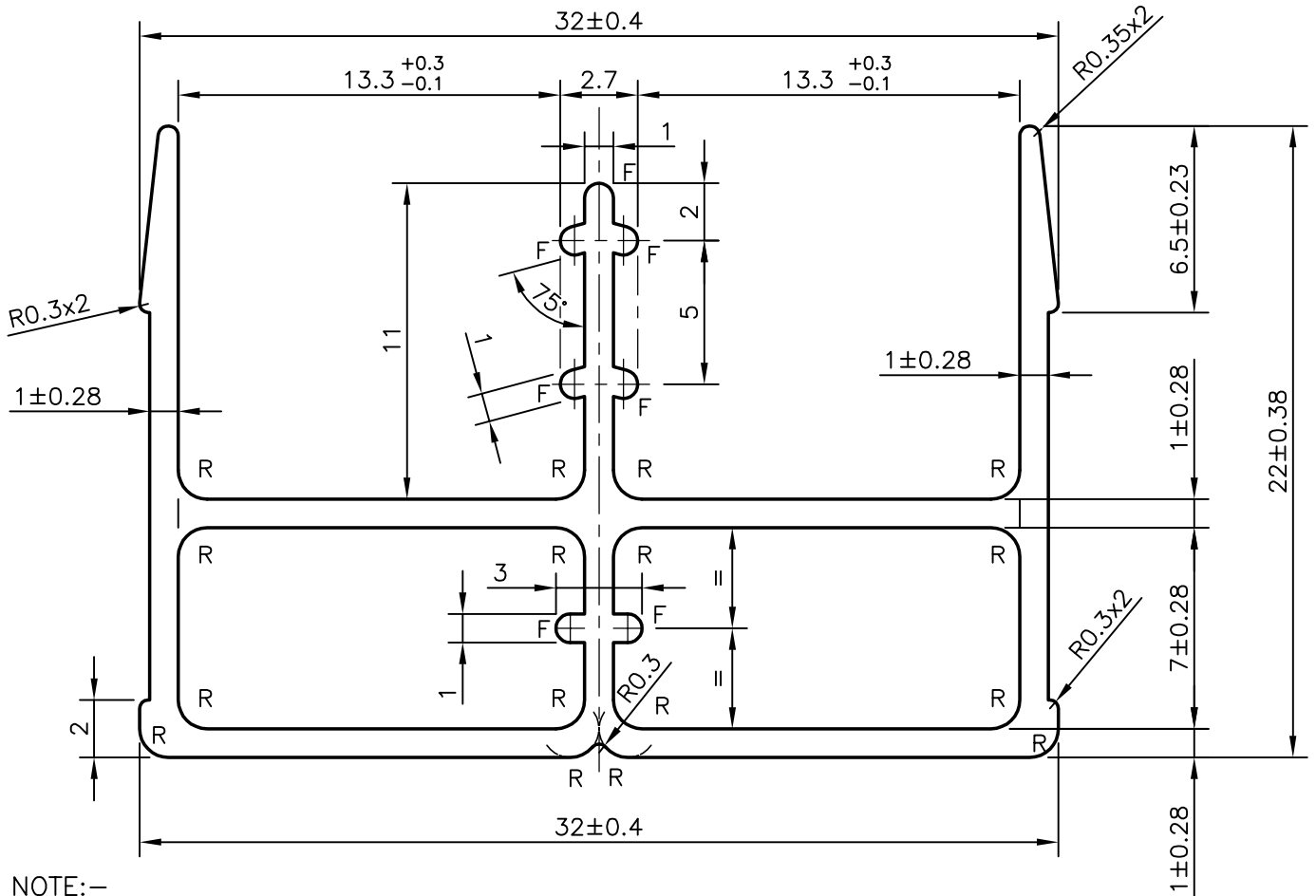

NOTE:-

- 1. R = R1.00 mm (16 PLACES)
- 2. F = FULL RADIUS (7 PLACES)



SYMBOL OF QUALITY
AN ISO 9001 COMPANY

JINDAL ALUMINIUM LTD.
BANGALORE-560073 (INDIA)

	NAME	DATE
DRAWN	RAGHAVENDRA	14-08-2007
CHECKED		
APPROVED		
SCALE		4:1
AREA mm ²		128.607
PERIMETER mm.		157.374
WEIGHT kg/m		0.347
DRAWING No.	SECTION No.	
P-7417-2	-	
X710	X710	
35016	35016	

- 1. ALL DIMENSIONS ARE IN mm.
- 2. ROUND OFF ALL SHARP CORNERS WITH 0.40 mm.
- 3. TOLERANCES WILL BE AS PER IS:6477-1983 UNLESS OTHERWISE SPECIFIED

PARTY'S NAME	ALKOSIGN DISPLAY SYSTEMS, MUMBAI
PARTY'S DRAWING No.	SECTION 'B'
ALLOY & TEMPER	HE9 WP
DESCRIPTION	DISPLAY SECTION