

P-9429-1

35017

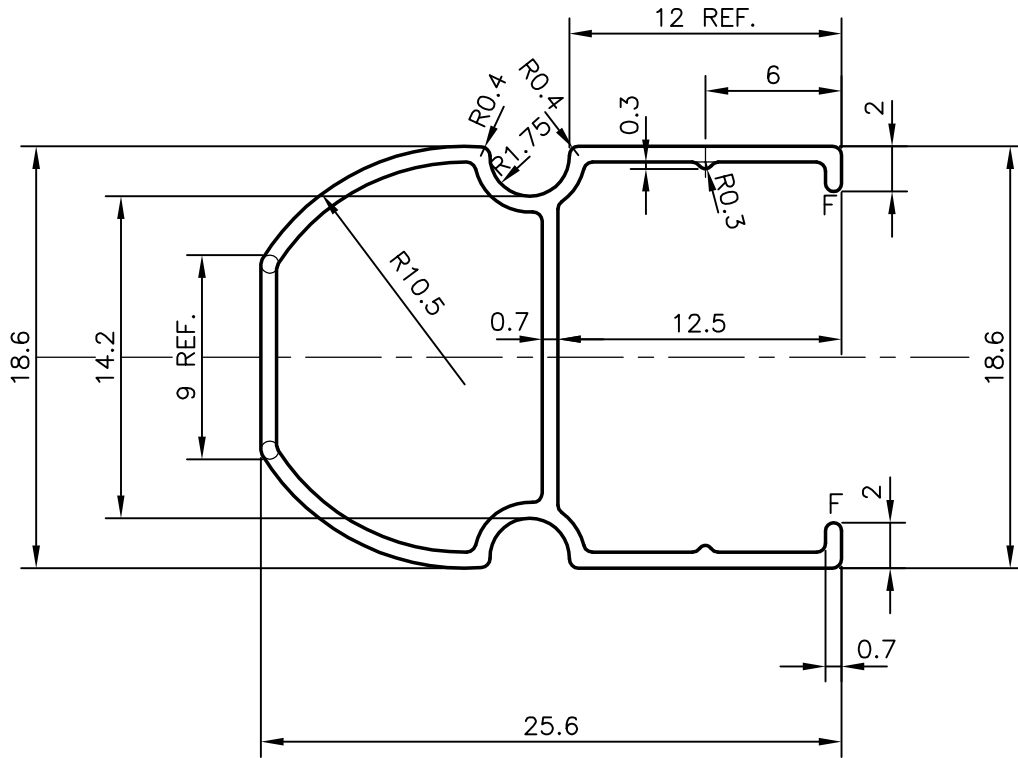
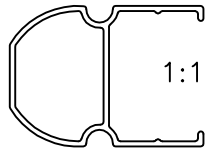

AVERAGE WEIGHT 0.600 Kg/ PIECES

F= FULL RADIUS
GENERAL WALL THICKNESS 0.7mm



SYMBOL OF QUALITY
AN ISO 9001 COMPANY

JINDAL ALUMINIUM LTD.
BANGALORE-560073 (INDIA)

	NAME	DATE
DRAWN	J.P.KAUSHIK	13-11-2009
CHECKED		
APPROVED		

1. ALL DIMENSIONS ARE IN mm.
2. ROUND OFF ALL SHARP CORNERS WITH 0.40 mm.
3. TOLERANCES WILL BE AS PER IS:6477-1983 UNLESS OTHERWISE SPECIFIED

SCALE	3:1
AREA mm ²	58.41
PERIMETER mm.	114.386
WEIGHT kg/m	0.164

PARTY'S NAME	GENERAL CATEGORY, DELHI MARKET
PARTY'S DRAWING No.	AS PER SAMPLE
ALLOY & TEMPER	HE9 WP
DESCRIPTION	DISPLAY SECTION

DRAWING No.	SECTION No.
P-9429-1	-
35017	35017