

P-7838-1

X781

35019

DETAIL OF "A"  
SCALE 4:1

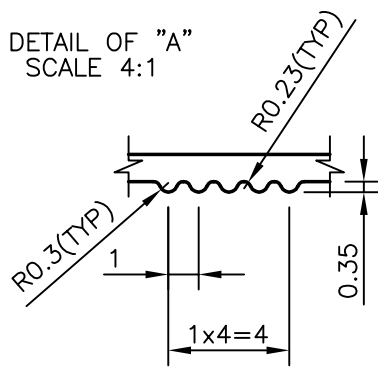

SCALE 1:1

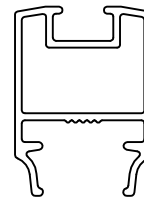

MATCHING SECTION

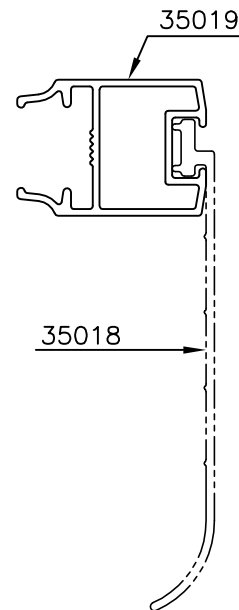
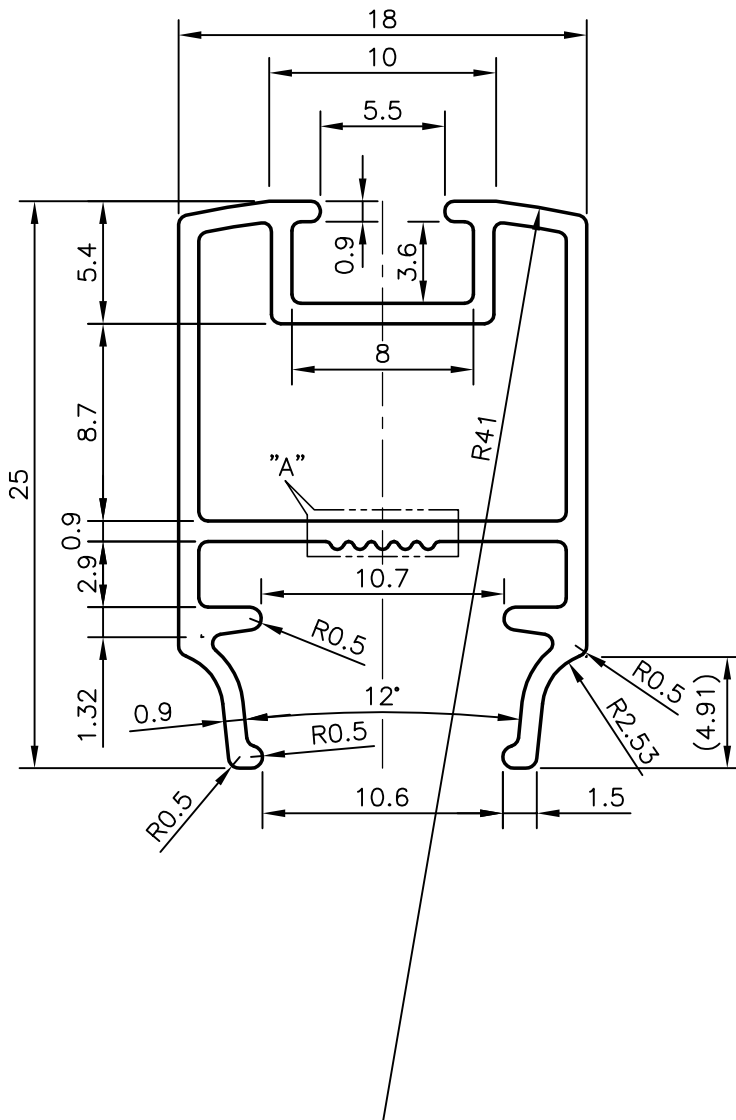

UNSPECIFIED WALL THICKNESS = 0.90 mm



SYMBOL OF QUALITY  
AN ISO 9001 COMPANY

**JINDAL ALUMINIUM LTD.**  
BANGALORE-560073 (INDIA)

	NAME	DATE
DRAWN	PRASANN. H	01-02-2008
CHECKED		
APPROVED		

1. ALL DIMENSIONS ARE IN mm.
2. ROUND OFF ALL SHARP CORNERS WITH 0.40 mm.
3. TOLERANCES WILL BE AS PER IS:6477-1983 UNLESS OTHERWISE SPECIFIED

SCALE	3:1
AREA mm <sup>2</sup>	102.138
PERIMETER mm.	128.921
WEIGHT kg/m	0.253

PARTY'S NAME ALKOSIGN DISPLAY SYSTEMS, MUMBAI

DRAWING No. SECTION No.

PARTY'S DRAWING No. AS PER DRAWING

P-7838-1 -

ALLOY & TEMPER HE9 WP

X781 X781

DESCRIPTION MISC. SECTION

35019 35019