

P-10115

S2568

35029

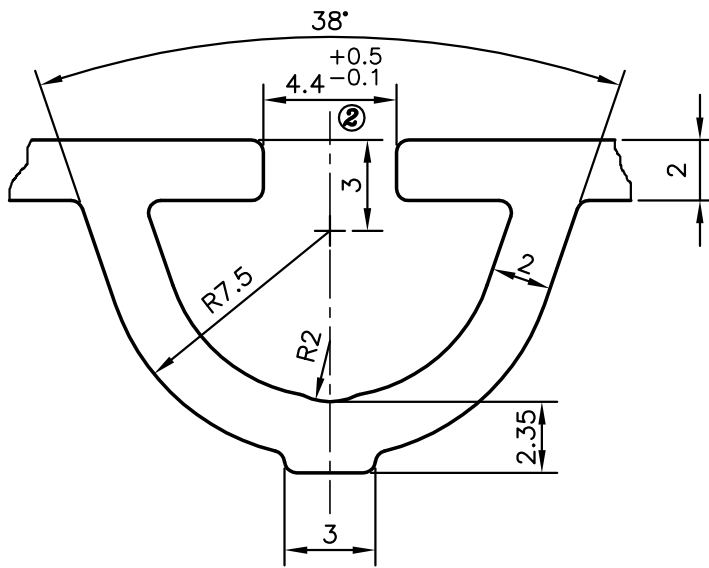

DETAIL OF "A"  
SCALE 4:1

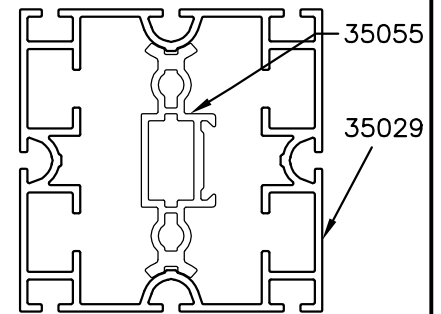
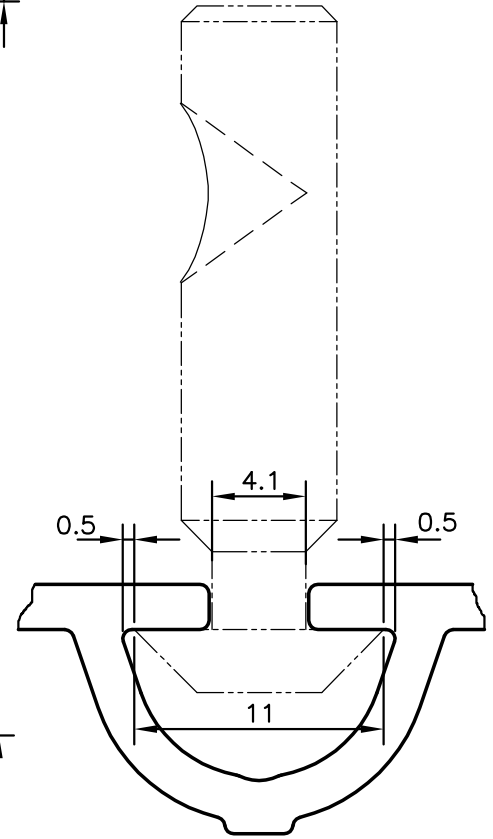
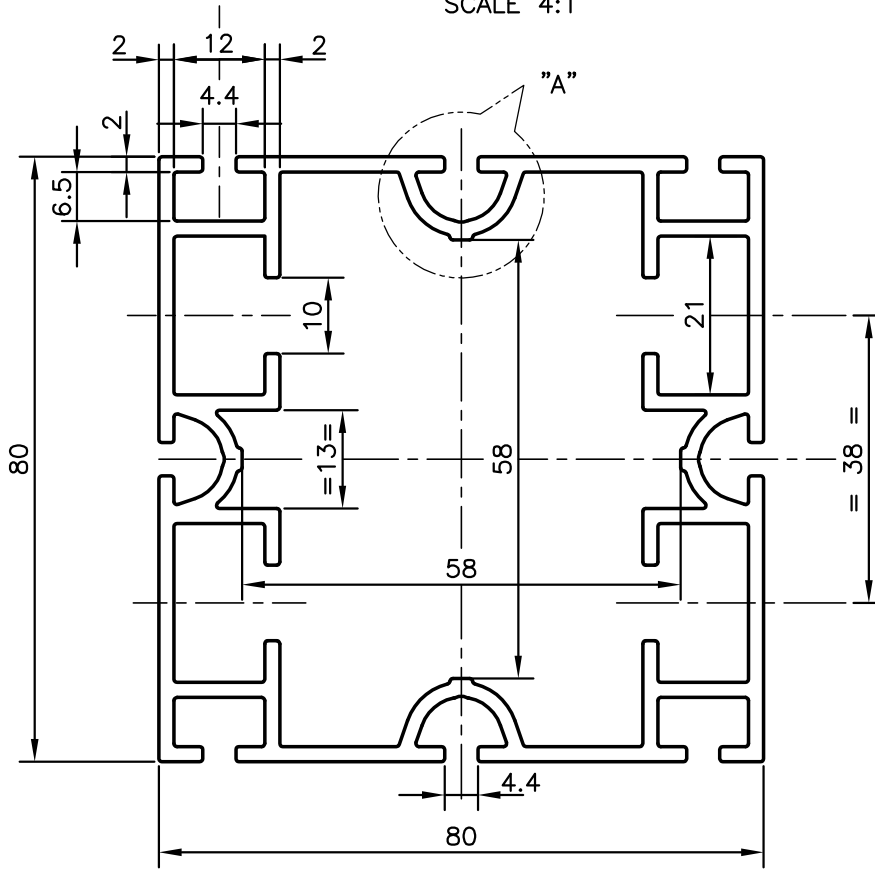

**ISSUE (2) :-**

TOLERANCE ADDED ON DIMENSION  $4.4^{+0.5}_{-0.1}$  mm.

UNSPECIFIED WALL THICKNESS 2.0 mm (TYP)



SYMBOL OF QUALITY  
AN ISO 9001 COMPANY

**JINDAL ALUMINIUM LTD.**  
BANGALORE-560073 (INDIA)

	NAME	DATE
DRAWN	PARVESH	10-01-2013
CHECKED		
APPROVED	S.S.GARG	12-01-2013
SCALE		1:1
AREA mm <sup>2</sup>		1088.038
PERIMETER mm.		545.468
WEIGHT kg/m		2.938
DRAWING No.	SECTION No.	
P-10115	-	
S2568	S2568	
35029	35029(ISSUE-2)	

1. ALL DIMENSIONS ARE IN mm.
2. ROUND OFF ALL SHARP CORNERS WITH 0.4 mm.
3. TOLERANCES WILL BE AS PER IS:6477-1983 UNLESS OTHERWISE SPECIFIED

PARTY'S NAME	EXPRO EVENTS & EXHIBITS, NEW DELHI
PARTY'S DRAWING No.	AS PER SAMPLE
ALLOY & TEMPER	HE9WP
DESCRIPTION	DISPLAY SECTION