

P-9404

S2198

35042

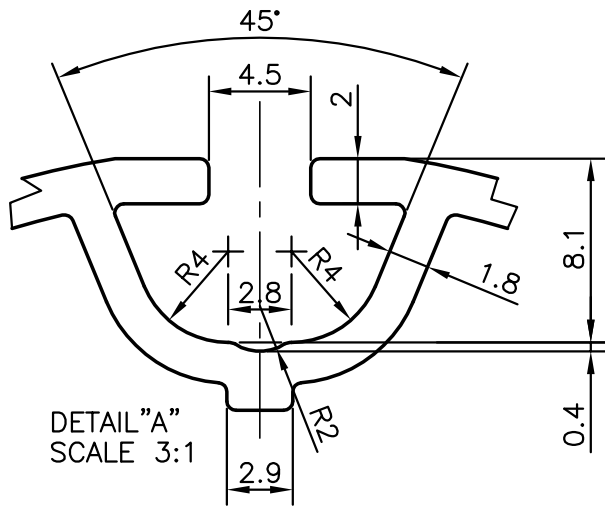

DETAIL "A"  
SCALE 3:1

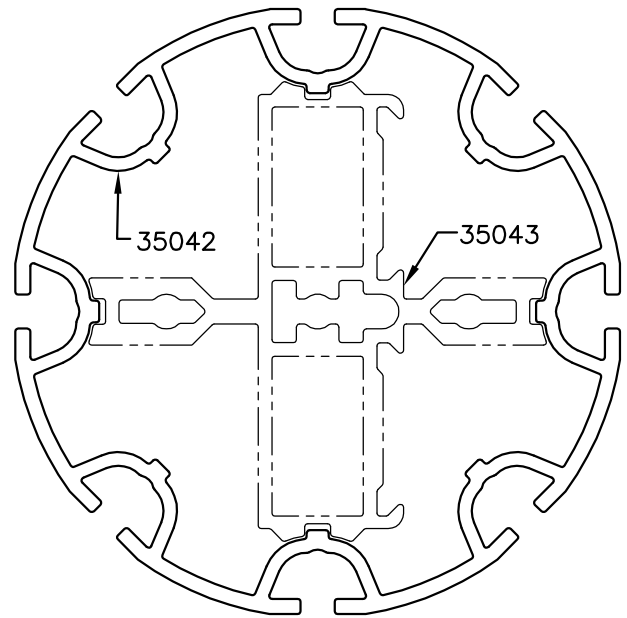

MATCHING SECTION  
SCALE 1:1

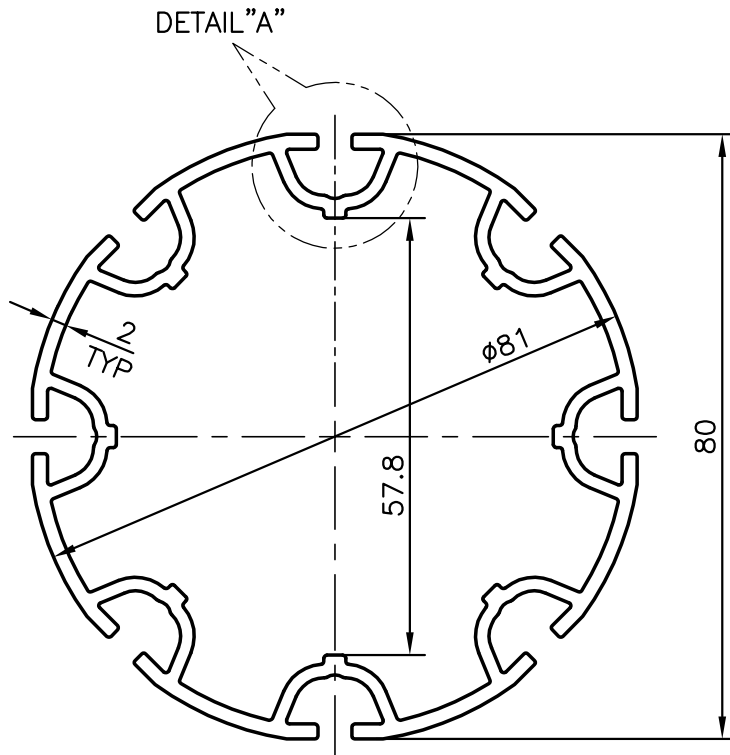

DETAIL "A"



SYMBOL OF QUALITY  
AN ISO 9001 COMPANY

**JINDAL ALUMINIUM LTD.**  
BANGALORE-560073 (INDIA)

	NAME	DATE
DRAWN	RAGHAVENDRA	16-07-2009
CHECKED		
APPROVED		

1. ALL DIMENSIONS ARE IN mm.
2. ROUND OFF ALL SHARP CORNERS WITH 0.40 mm.
3. TOLERANCES WILL BE AS PER IS:6477-1983 UNLESS OTHERWISE SPECIFIED

SCALE	1:1
AREA mm <sup>2</sup>	769.515
PERIMETER mm.	469.469
WEIGHT kg/m	2.078

PARTY'S NAME	INSTA EXHIBITION PVT. LTD., HARIDWAR
PARTY'S DRAWING No.	AS PER SAMPLE
ALLOY & TEMPER	HE9 WP
DESCRIPTION	DISPLAY SECTION

DRAWING No.	SECTION No.
P-9404	-
S2198	S2198
35042	35042