

P-11760

S3391

35063

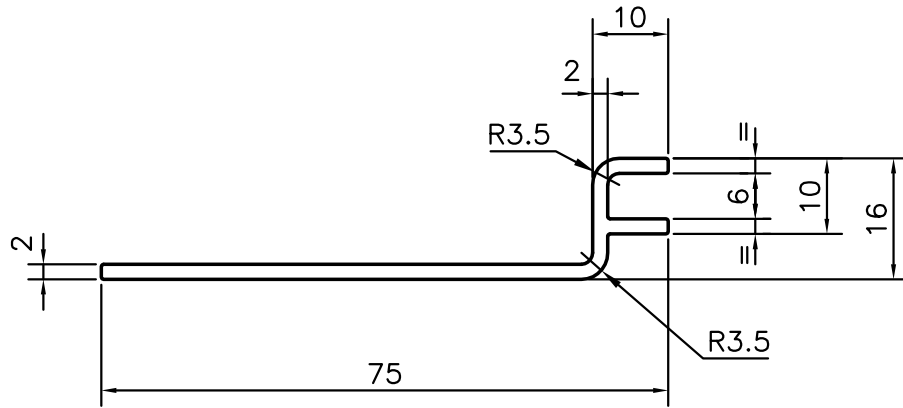

SYMBOL OF QUALITY
AN ISO 9001 COMPANY

JINDAL ALUMINIUM LTD.
BANGALORE-560073 (INDIA)

	NAME	DATE
DRAWN	PARVESH	16-05-2012
CHECKED		
APPROVED	S.S.GARG	11-07-2012
SCALE		1:1
AREA mm ²		189.631
PERIMETER mm.		192.678
WEIGHT kg/m		0.512
DRAWING No.	SECTION No.	
P-11760	-	
S3391	S3391	
35063	35063	

1. ALL DIMENSIONS ARE IN mm.
2. ROUND OFF ALL SHARP CORNERS WITH 0.30 mm.
3. TOLERANCES WILL BE AS PER DIN:EN-12020-2, UNLESS OTHERWISE SPECIFIED

PARTY'S NAME	ELECTROSPARK, GURGAON
PARTY'S DRAWING No.	DIFFUSER BOTTOM STOPPER-4
ALLOY & TEMPER	6063 T6
DESCRIPTION	DIFFUSER BOTTOM STOPPER PROFILE