

P-11762-1

S3393

35064

EXPOSED SURFACE

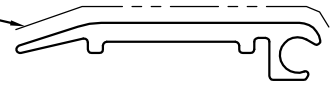

SCALE;- 1:1

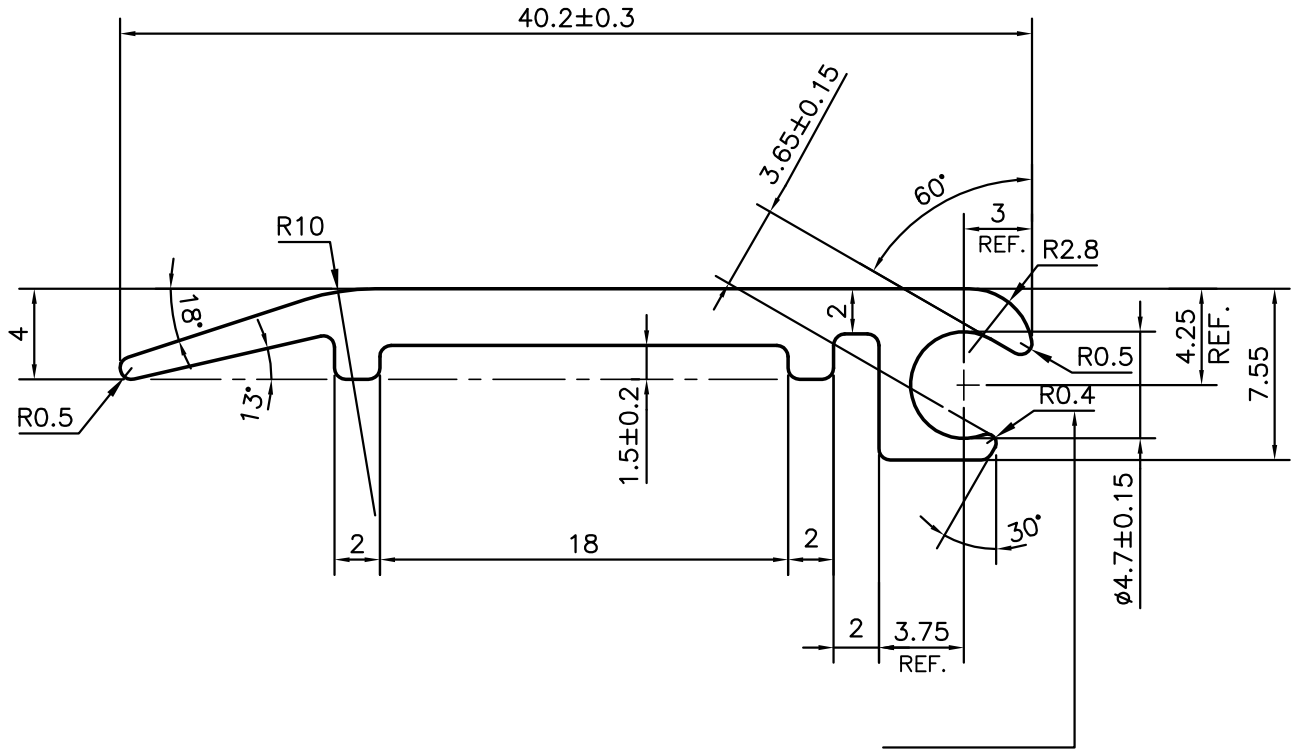

SYMBOL OF QUALITY  
AN ISO 9001 COMPANY

**JINDAL ALUMINIUM LTD.**  
BANGALORE-560073 (INDIA)

	NAME	DATE
DRAWN	PARVESH	23-05-2012
CHECKED		
APPROVED	S.S.GARG	11-07-2012
SCALE		3:1
AREA mm <sup>2</sup>		104.923
PERIMETER mm.		104.618
WEIGHT kg/m		0.283
DRAWING No.	SECTION No.	
P-11762-1	-	
S3393	S3393	
35064	35064	

1. ALL DIMENSIONS ARE IN mm.
2. ROUND OFF ALL SHARP CORNERS WITH 0.50 mm.
3. TOLERANCES WILL BE AS PER DIN:EN-12020-2, UNLESS OTHERWISE SPECIFIED

PARTY'S NAME	ELECTROSPARK, GURGAON
PARTY'S DRAWING No.	DOOR HINGE-2
ALLOY & TEMPER	6063 T6
DESCRIPTION	DOOR HINGE PROFILE