

P-11776-1

S3394

35065

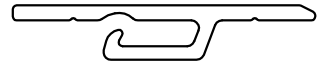

SCALE:- 1:1

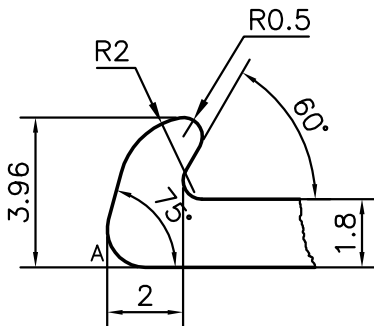
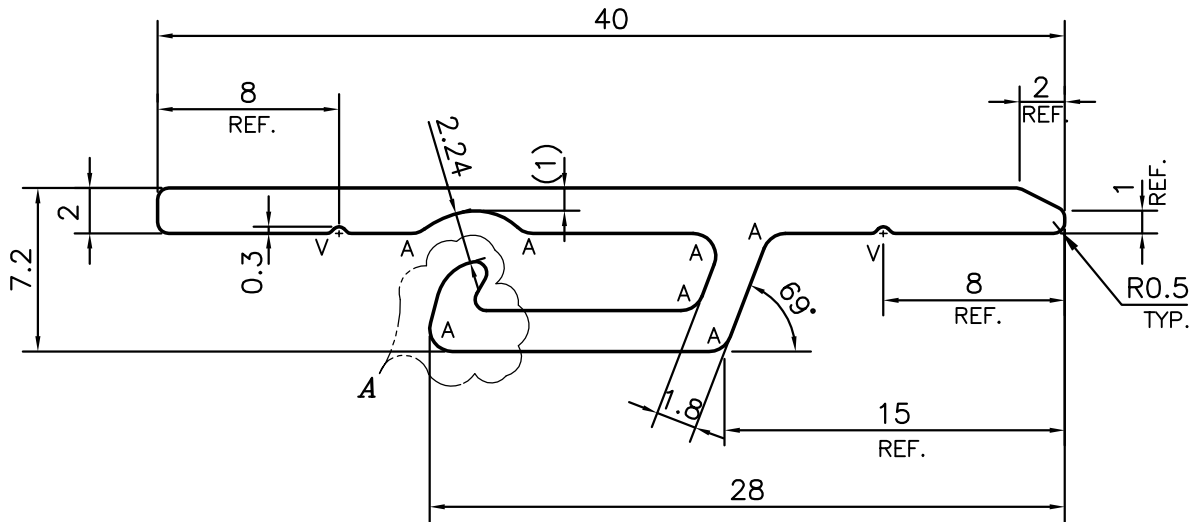

DETAIL OF "A"
SCALE 5:1

V = VEE GROOVE 0.3x90° (2 PLACES)
A = RADIUS 1 mm. (7 PLACES)



SYMBOL OF QUALITY
AN ISO 9001 COMPANY

JINDAL ALUMINIUM LTD.
BANGALORE-560073 (INDIA)

	NAME	DATE
DRAWN	PARVESH	05-06-2012
CHECKED		
APPROVED	S.S.GARG	11-07-2012
SCALE		3:1
AREA mm ²		109.657
PERIMETER mm.		118.765
WEIGHT kg/m		0.296
DRAWING No.	SECTION No.	
P-11776-1	-	
S3394	S3394	
35065	35065	

1. ALL DIMENSIONS ARE IN mm.
2. ROUND OFF ALL SHARP CORNERS WITH 0.50 mm.
3. TOLERANCES WILL BE AS PER DIN:EN-12020-2, UNLESS OTHERWISE SPECIFIED

PARTY'S NAME	ELECTROSPARK, GURGAON
PARTY'S DRAWING No.	POSTER HANGING BAR-5
ALLOY & TEMPER	6063 T6
DESCRIPTION	POSTER HANGING BAR PROFILE