

P-9656

X1236

35068

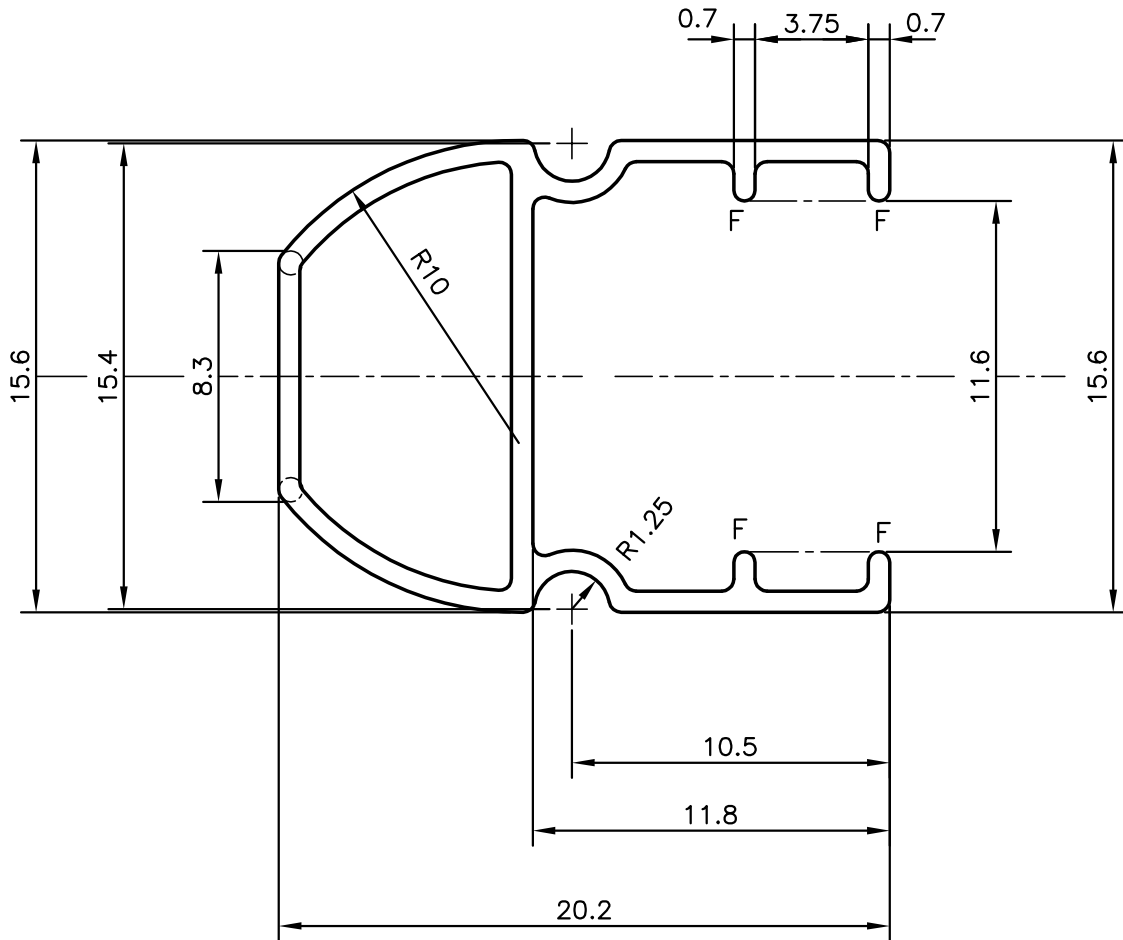
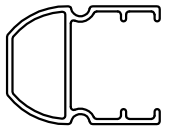

F = FULL RADIUS (4 PLACES)
GENERAL WALL THICKNESS 0.70 mm



SYMBOL OF QUALITY
AN ISO 9001 COMPANY

JINDAL ALUMINIUM LTD.
BANGALORE-560073 (INDIA)

	NAME	DATE
DRAWN	J.P.KAUSHIK	21-11-2009
CHECKED		
APPROVED		

SCALE	4:1
AREA mm ²	49.735
PERIMETER mm.	98.77
WEIGHT kg/m	0.134
DRAWING No.	SECTION No.
P-9656	-
X1236	X1236
35068	35068

1. ALL DIMENSIONS ARE IN mm.
2. ROUND OFF ALL SHARP CORNERS WITH 0.40 mm.
3. TOLERANCES WILL BE AS PER IS:6477-1983, UNLESS OTHERWISE SPECIFIED

PARTY'S NAME	PREMIER METAL CORPORATION, DELHI
PARTY'S DRAWING No.	AS PER SAMPLE
ALLOY & TEMPER	HE9 WP
DESCRIPTION	DISPLAY SECTION