

P-13157

35073

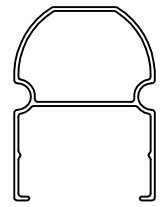

SCALE: - 1:1

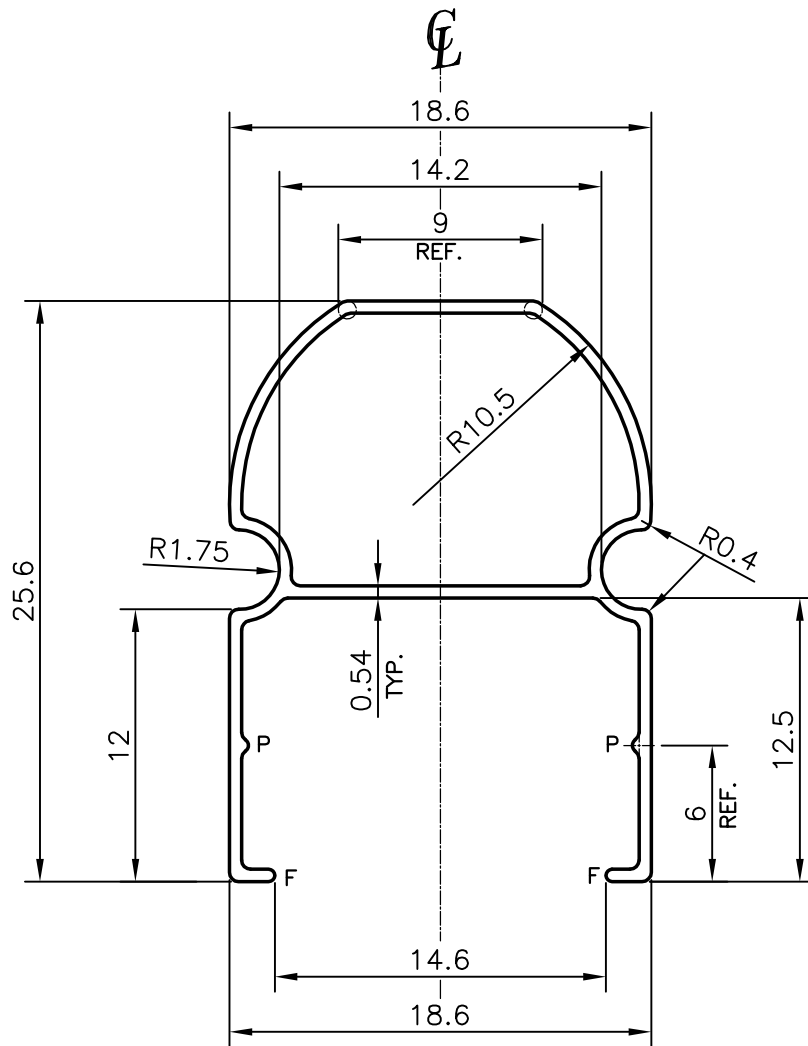

GENERAL WALL THICKNESS = 0.54mm

3658mm LONG PIECES IN 100kgs = 220 (AVERAGE)

F = FULL RADIUS (6 PLACES)

P = PIP 0.3x90° (2 PLACES)



SYMBOL OF QUALITY
AN ISO 9001 COMPANY

JINDAL ALUMINIUM LTD.
BANGALORE-560073 (INDIA)

	NAME	DATE
DRAWN	PARVESH	28-10-2013
CHECKED		
APPROVED	S.S.GARG	06-11-2013
SCALE		3:1
AREA mm ²		45.787
PERIMETER mm.		115.292
WEIGHT kg/m		0.124
DRAWING No.	SECTION No.	
P-13157	-	
35073	35073	

1. ALL DIMENSIONS ARE IN mm.
2. ROUND OFF ALL SHARP CORNERS WITH 0.40 mm.
3. TOLERANCES WILL BE AS PER IS:6477-1983, UNLESS OTHERWISE SPECIFIED

PARTY'S NAME	GENERAL CATEGORY, DELHI MARKET
PARTY'S DRAWING No.	LIGHTER OF SECTION No. 35017
ALLOY & TEMPER	HE9 WP
DESCRIPTION	DISPLAY SECTION