

P-12988

35075

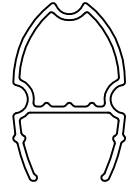

SCALE: - 1:1

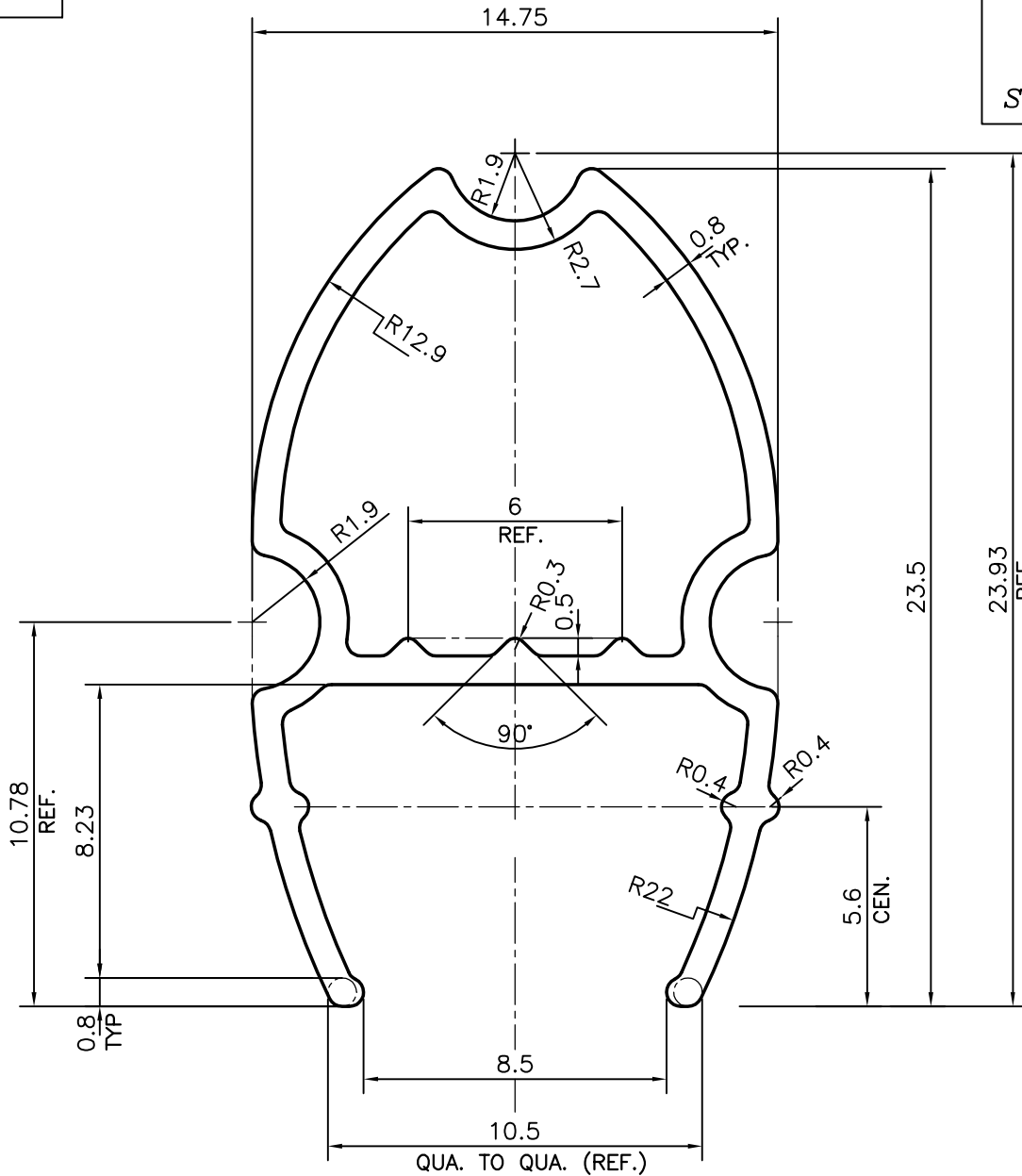

TOLERANCES ON OVERALL WIDTHS & WIDTHS ACROSS FLATS OF BARS, & REGULAR SECTIONS

| | | | |
|---------------------|----------------------|----------------------|-----------------------|
| UPTO 6.40mm - ±0.20 | UPTO 32.0mm - ±0.38 | UPTO 120.0mm - ±0.85 | UPTO 320.00mm - ±1.70 |
| UPTO 10.0mm - ±0.23 | UPTO 50.0mm - ±0.46 | UPTO 160.0mm - ±1.02 | |
| UPTO 12.0mm - ±0.25 | UPTO 60.0mm - ±0.53 | UPTO 200.0mm - ±1.14 | |
| UPTO 16.0mm - ±0.28 | UPTO 80.0mm - ±0.69 | UPTO 250.0mm - ±1.40 | |
| UPTO 25.0mm - ±0.30 | UPTO 100.0mm - ±0.75 | UPTO 300.0mm - ±1.65 | |



SYMBOL OF QUALITY
AN ISO 9001 COMPANY

JINDAL ALUMINIUM LTD.
BANGALORE-560073 (INDIA)

| | | |
|----------|-------------|------------|
| | NAME | DATE |
| DRAWN | J.P.KAUSHIK | 29-08-2013 |
| CHECKED | | |
| APPROVED | S.S.GARG | 07-11-2013 |

1. ALL DIMENSIONS ARE IN mm.
2. ROUND OFF ALL SHARP CORNERS WITH 0.40 mm.
3. TOLERANCES WILL BE AS PER IS:6477-1983 , UNLESS OTHERWISE SPECIFIED

| | |
|----------------------|--------|
| SCALE | 5:1 |
| AREA mm ² | 57.898 |
| PERIMETER mm. | 93.661 |
| WEIGHT kg/m | 0.156 |

| | |
|---------------------|-----------------------------------|
| PARTY'S NAME | GENERAL CATEGORY , KOLKATA MARKET |
| PARTY'S DRAWING No. | AS PER SAMPLE |
| ALLOY & TEMPER | HE9 WP |
| DESCRIPTION | DISPLAY SECTION |

| | |
|-------------|-------------|
| DRAWING No. | SECTION No. |
| P-12988 | - |
| 35075 | 35075 |