

P-11370-2
S3131
35077

EXPOSED SURFACE

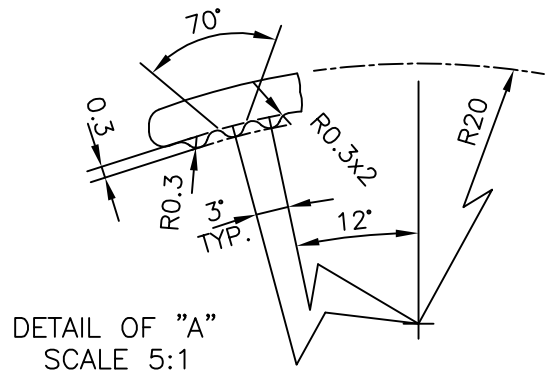
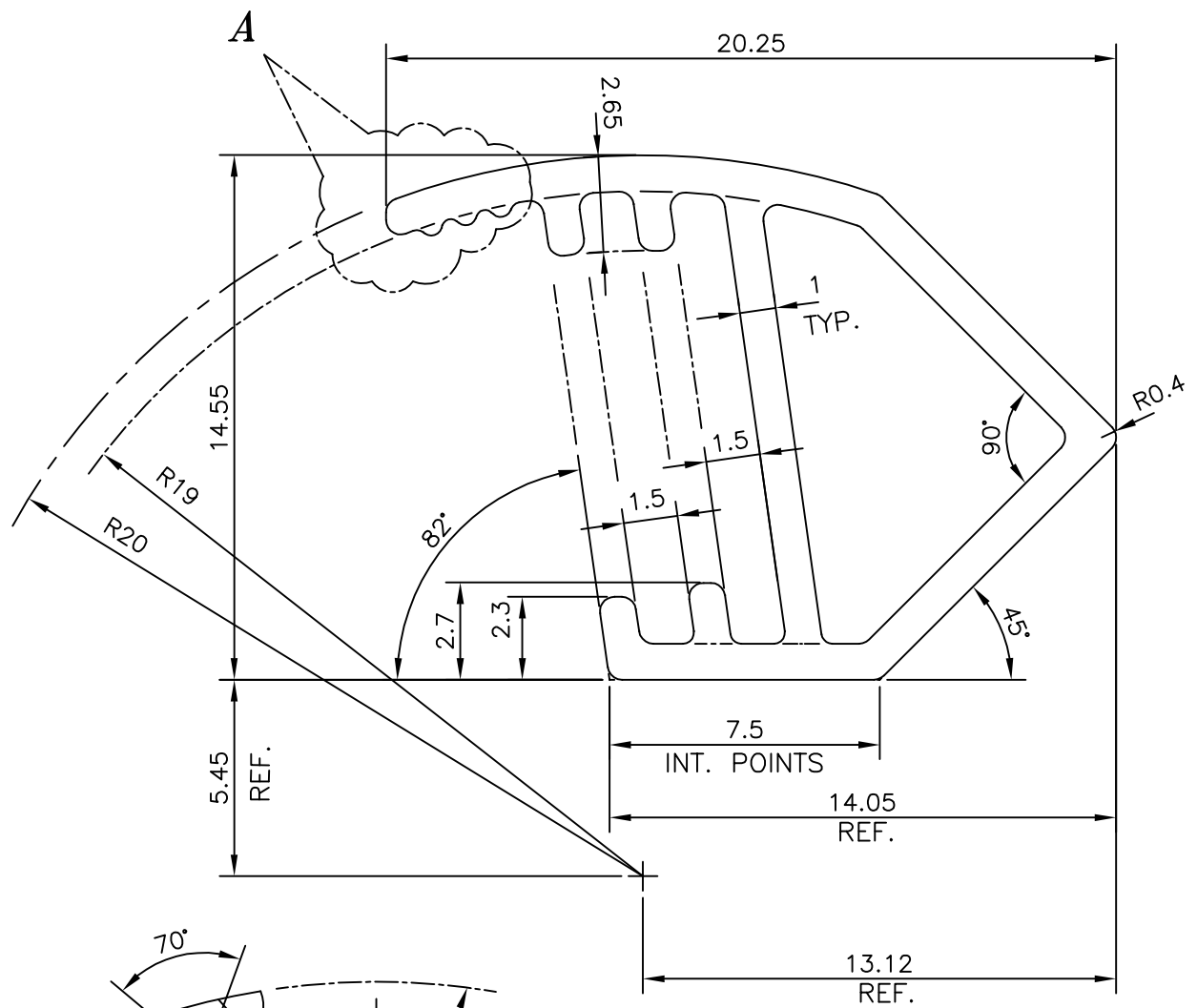
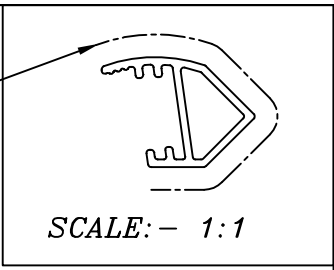

JINDAL ALUMINIUM LTD.
BANGALORE-560073 (INDIA)

	NAME	DATE
DRAWN	PARVESH	16-12-2011
CHECKED		
APPROVED	S.S.GARG	23-12-2011
SCALE		5:1
AREA mm ²		57.972
PERIMETER mm.		79.358
WEIGHT kg/m		0.157
DRAWING No.	SECTION No.	
P-11370-2		
S3131	S3131	
35077	35077	

1. ALL DIMENSIONS ARE IN mm. 2. ROUND OFF ALL SHARP CORNERS WITH 0.40 mm. 3. TOLERANCES WILL BE AS PER IS:6477-1983, UNLESS OTHERWISE SPECIFIED	
PARTY'S NAME	DISHA RETAIL FIXTURES PVT. LTD., BANGALORE
PARTY'S DRAWING No.	HA 00 00 379A (REV 0)
ALLOY & TEMPER	HE9 WP
DESCRIPTION	MISC. SECTION