

P-11420-3

S3151

35079

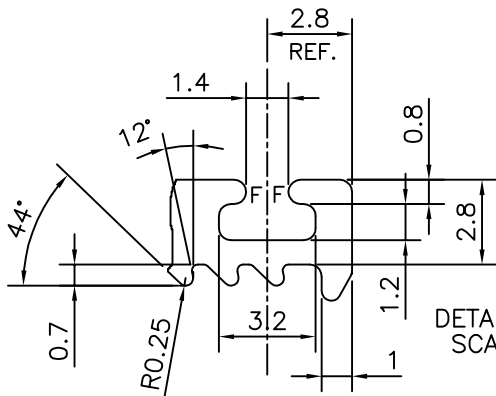
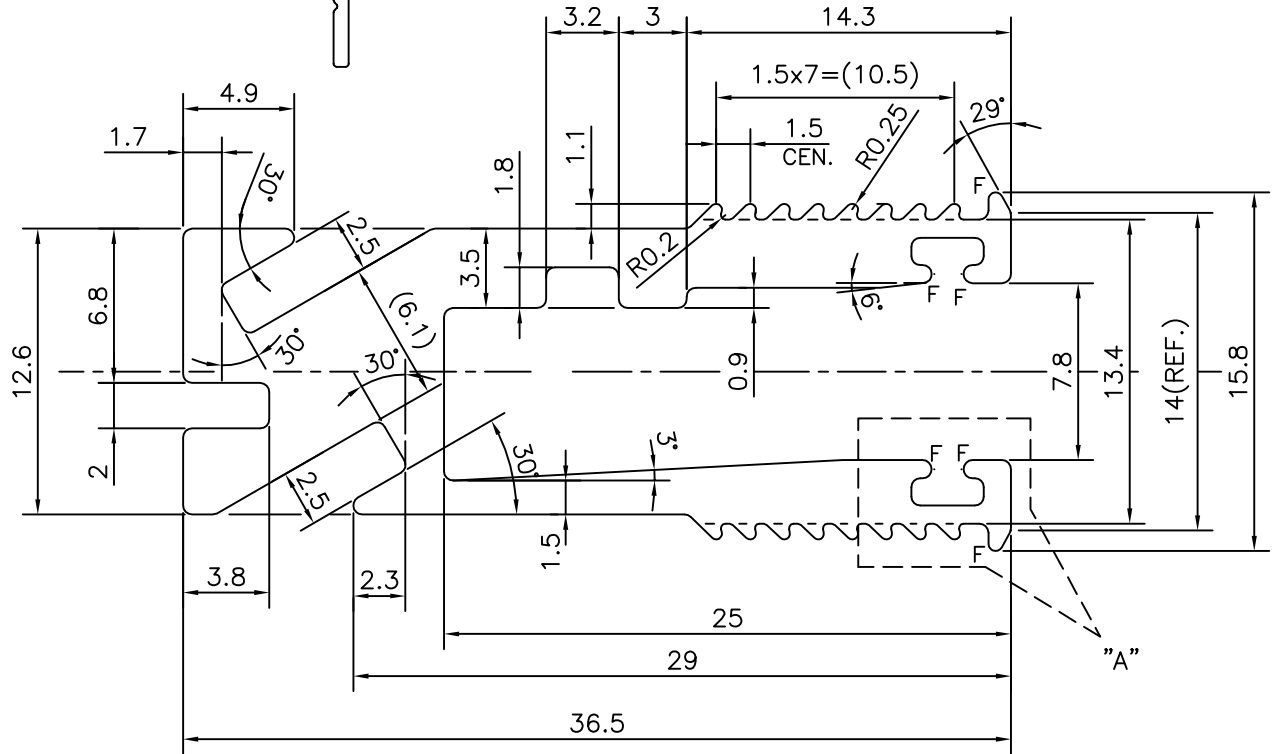
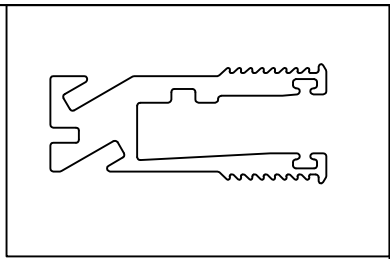
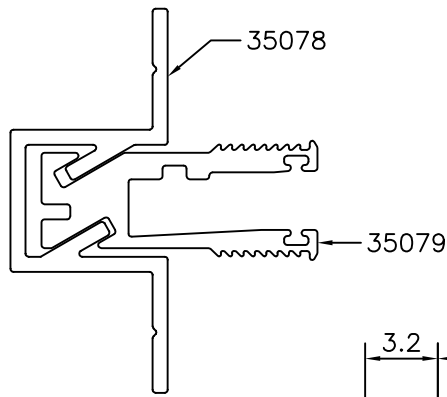

DETAIL OF "A"  
SCALE 4:1 F = FULL RADIUS ( 6 PLACES )



SYMBOL OF QUALITY  
AN ISO 9001 COMPANY

**JINDAL ALUMINIUM LTD.**  
BANGALORE-560073 (INDIA)

	NAME	DATE
DRAWN	J.P.KAUSHIK	12-01-2012
CHECKED		
APPROVED	S.S.GARG	14-01-2012
SCALE		3:1
AREA mm <sup>2</sup>		233.5
PERIMETER mm.		204.928
WEIGHT kg/m		0.630
DRAWING No.	SECTION No.	
P-11420-3	-	
S3151	S3151	
35079	35079	

1. ALL DIMENSIONS ARE IN mm. 2. ROUND OFF ALL SHARP CORNERS WITH 0.40 mm. 3. TOLERANCES WILL BE AS PER IS:3965-1981 UNLESS OTHERWISE SPECIFIED	
PARTY'S NAME	DISHA RETAIL FIXTURES PVT. LTD., BANGALORE
PARTY'S DRAWING No.	DRF-02817-001 (REV. 0)
ALLOY & TEMPER	HE9 WP
DESCRIPTION	MISC. SECTION