

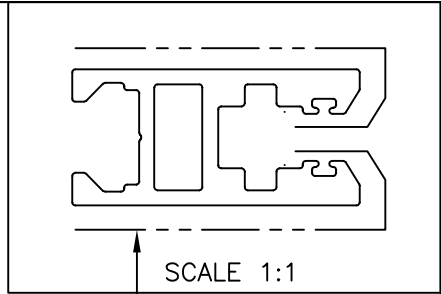

P-11448-1
S3152
35080

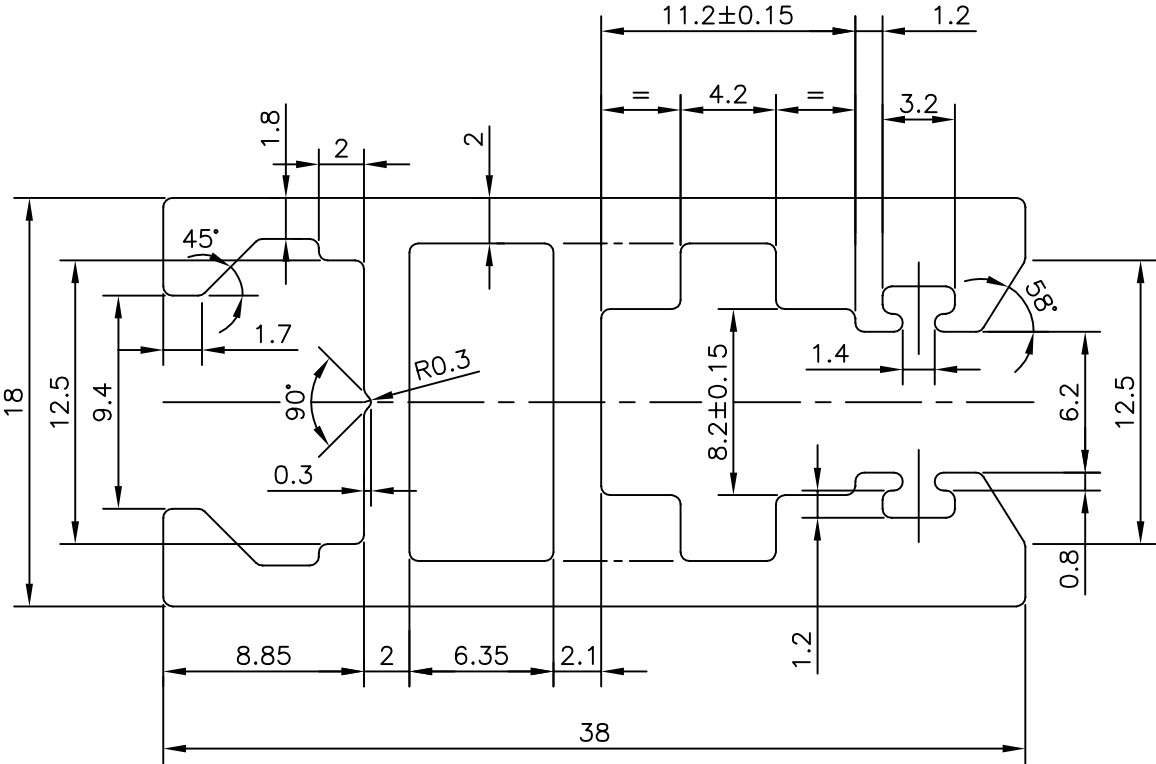

EXPOSED SURFACE
BETTER FINISH REQUIRED



 SYMBOL OF QUALITY AN ISO 9001 COMPANY	JINDAL ALUMINIUM LTD. BANGALORE-560073 (INDIA)	NAME		DATE
		DRAWN	PARVESH	09-01-2012
1. ALL DIMENSIONS ARE IN mm. 2. ROUND OFF ALL SHARP CORNERS WITH 0.40 mm. 3. TOLERANCES WILL BE AS PER IS:6477-1983 UNLESS OTHERWISE SPECIFIED		CHECKED		
		APPROVED	S.S.GARG	16-01-2012
PARTY'S NAME		SCALE		3:1
		AREA mm ²		307.273
PARTY'S DRAWING No.		PERIMETER mm.		194.983
		WEIGHT kg/m		0.830
ALLOY & TEMPER		DRAWING No.		SECTION No.
		P-11448-1		-
DESCRIPTION		S3152		S3152
		35080		35080