

P-15086

35089

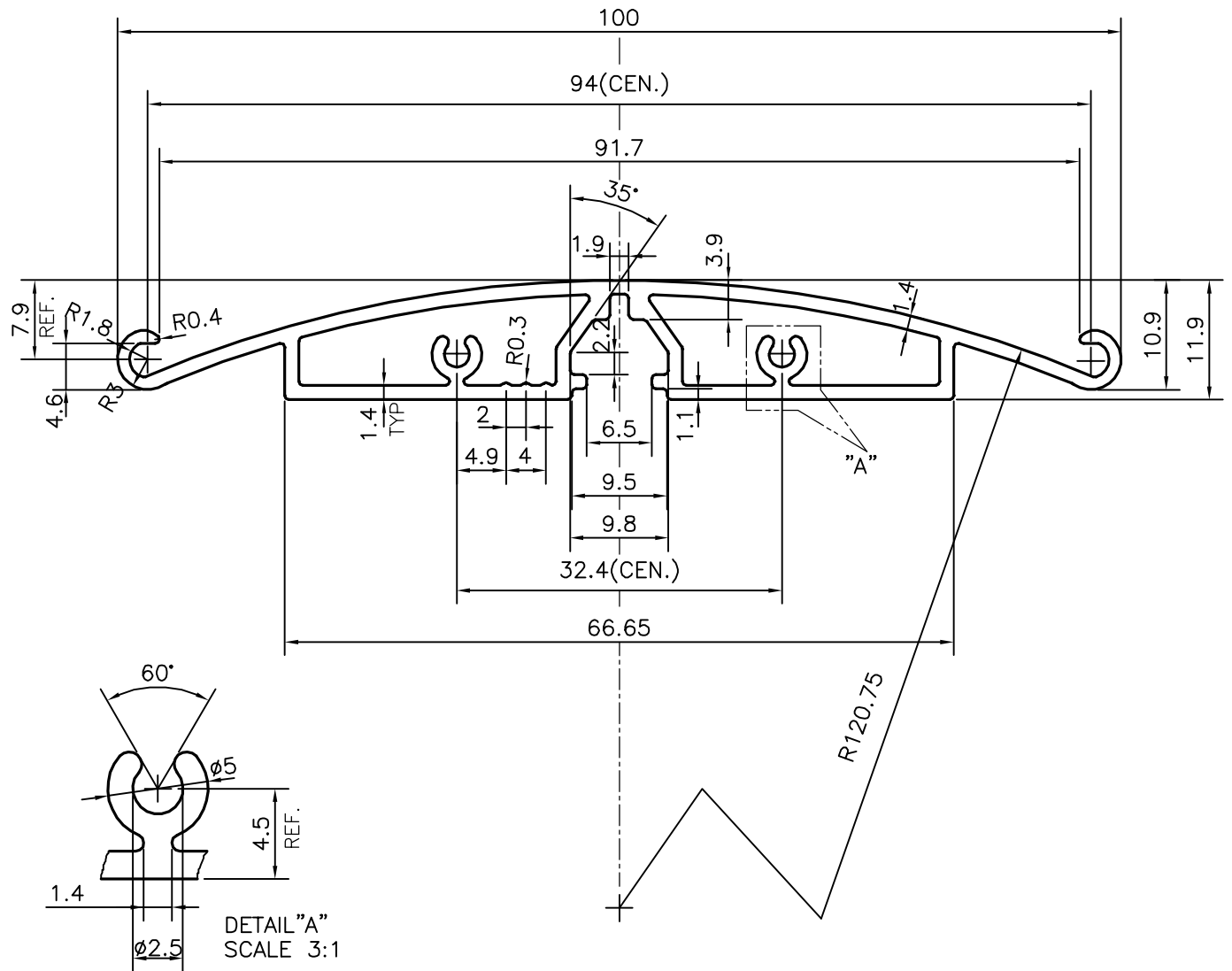
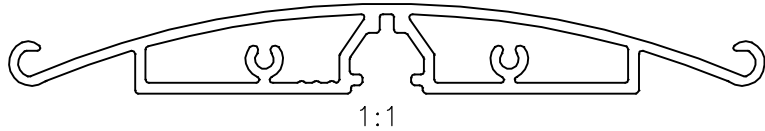

SYMBOL OF QUALITY
AN ISO 9001 COMPANY

JINDAL ALUMINIUM LTD.
BANGALORE-560073 (INDIA)

	NAME	DATE
DRAWN	J.P.KAUSHIK	26-08-2015
CHECKED		
APPROVED	S.S.GARG	28-08-2015
SCALE		1.5:1
AREA mm ²		312.59
PERIMETER mm.		260.588
WEIGHT kg/m		0.844
DRAWING No.	SECTION No.	
P-15086	-	
35089	35089	

1. ALL DIMENSIONS ARE IN mm.
2. ROUND OFF ALL SHARP CORNERS WITH 0.40 mm.
3. TOLERANCES WILL BE AS PER IS:6477-1983 , UNLESS OTHERWISE SPECIFIED

PARTY'S NAME	GENERAL CATEGORY, DELHI MARKET
PARTY'S DRAWING No.	AS PER SAMPLE
ALLOY & TEMPER	HE9 WP
DESCRIPTION	DISPLAY SECTION