

P-12874
S3797
35093

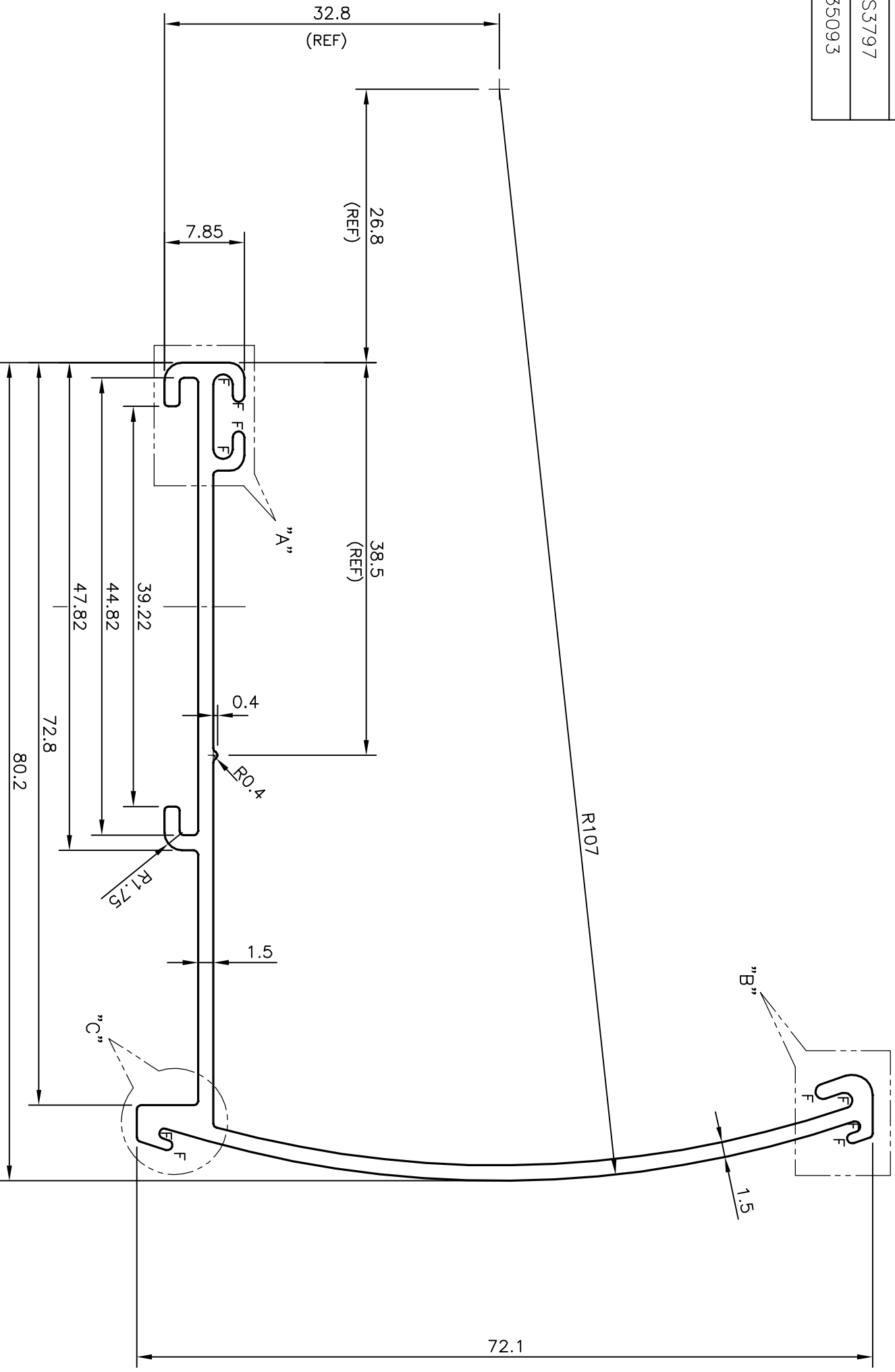

F = FULL RADIUS (10 PLACES)

SCALE 1:1

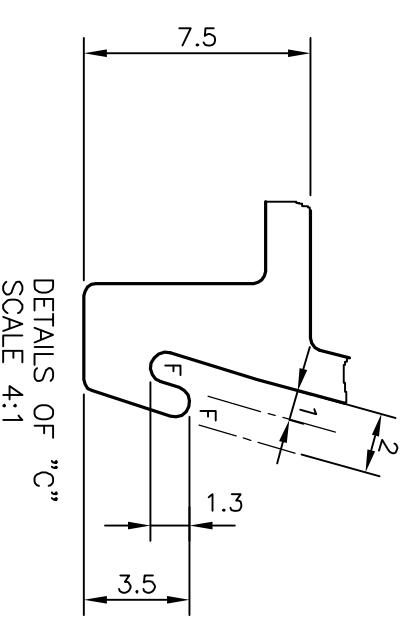
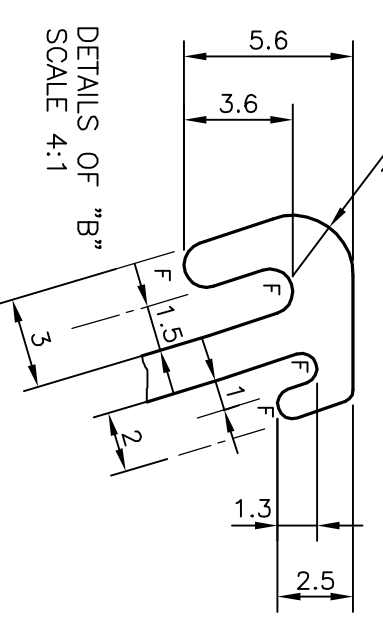
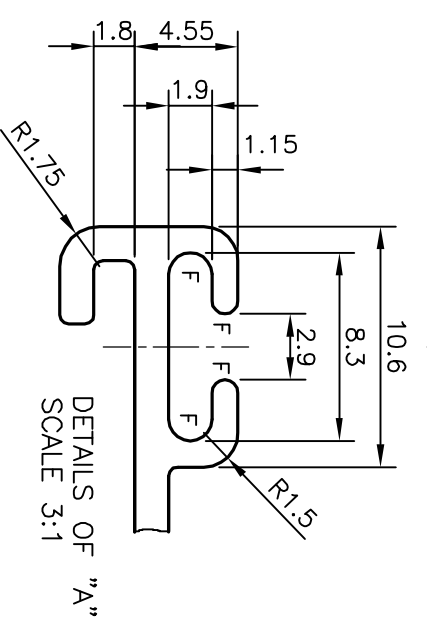
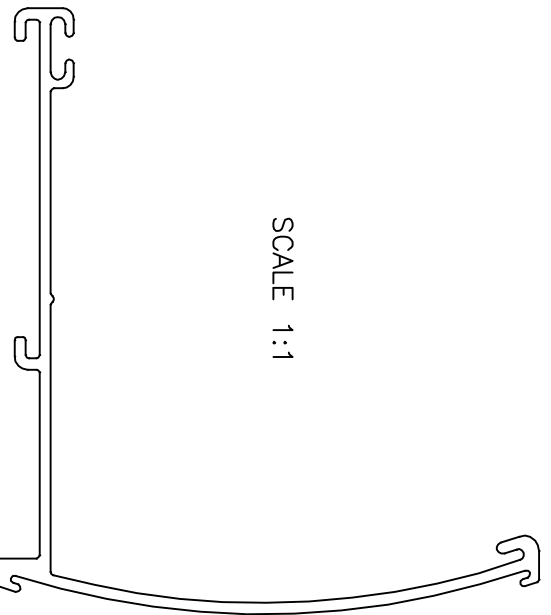

TOLERANCES ON OVERALL WIDTHS & WIDTHS ACROSS FLATS OF BARS, & REGULAR SECTIONS			
UPTO 6.40mm - ±0.20	UPTO 32.0mm - ±0.38	UPTO 120.0mm - ±0.85	UPTO 320.00mm - ±1.70
UPTO 10.0mm - ±0.23	UPTO 50.0mm - ±0.46	UPTO 160.0mm - ±1.02	
UPTO 12.0mm - ±0.25	UPTO 60.0mm - ±0.53	UPTO 200.0mm - ±1.14	
UPTO 16.0mm - ±0.28	UPTO 80.0mm - ±0.69	UPTO 250.0mm - ±1.40	
UPTO 25.0mm - ±0.30	UPTO 100.0mm - ±0.75	UPTO 300.0mm - ±1.65	

<p>SYMBOL OF QUALITY AN ISO 9001 COMPANY</p>		<p>JINDAL ALUMINIUM LTD. BANGALORE-560073 (INDIA)</p>	
<p>1. ALL DIMENSIONS ARE IN mm. 2. ROUND OFF ALL SHARP CORNERS WITH 0.40 mm. 3. TOLERANCES WILL BE AS PER IS:3965-1981 UNLESS OTHERWISE SPECIFIED</p>		<p>DRAWN SRIYATHSA 29-06-2013 CHECKED APPROVED S.S.GARG 03-07-2013</p>	
<p>PARTY'S NAME MAC LIFESTYLE PRODUCT PVT. LTD., NEW DELHI</p>		<p>SCALE 2:1</p>	
<p>PARTY'S DRAWING No. AS PER SAMPLE & SECTION NO. 29456</p>		<p>AREA mm² 277.132</p>	
<p>ALLOY & TEMPER HE9 WP</p>		<p>PERIMETER mm. 359.647</p>	
<p>DESCRIPTION MISC. SECTION</p>		<p>WEIGHT kg/m 0.748</p>	
		<p>DRAWING No. SECTION No.</p>	

PARTY'S NAME	MAC LIFESTYLE PRODUCT PVT. LTD., NEW DELHI
PARTY'S DRAWING No.	AS PER SAMPLE & SECTION NO. 29456
ALLOY & TEMPER	HE9 WP
DESCRIPTION	MISC. SECTION