

P-11509-3

X1578

35096



SCALE :- 1:1

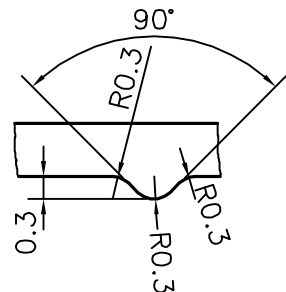
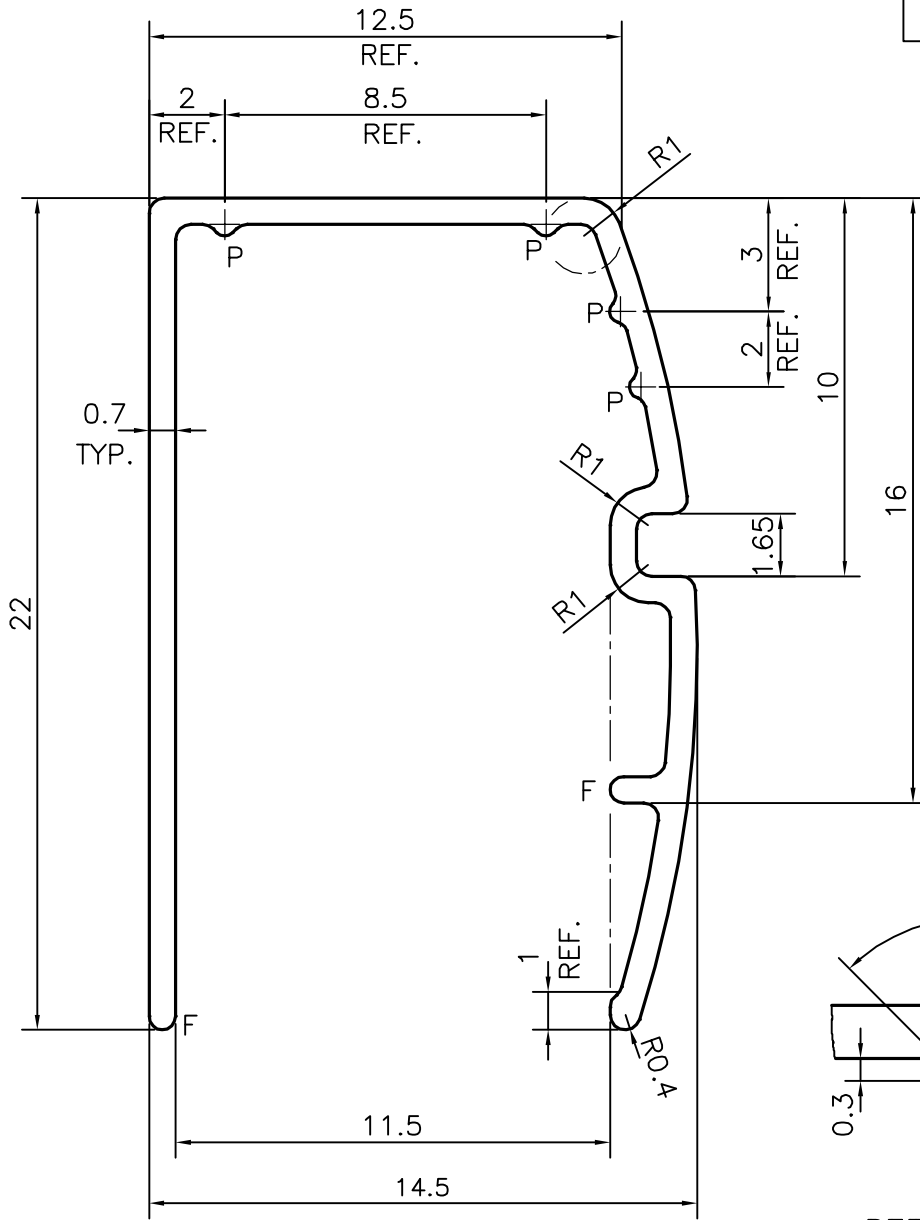

DETAIL OF PIP
SCALE :- 10:1

F = FULL RADIUS (2 PLACES)
P = PIP 0.3x90° (4 PLACES)



SYMBOL OF QUALITY
AN ISO 9001 COMPANY

JINDAL ALUMINIUM LTD.
BANGALORE-560073 (INDIA)

	NAME	DATE
DRAWN	PARVESH	06-02-2012
CHECKED		
APPROVED	S.S. GARG	13-02-2012
SCALE		5:1
AREA	mm ²	41.974
PERIMETER	mm.	117.741
WEIGHT	kg/m	0.113
DRAWING No.	SECTION No.	
P-11509-3	-	
X1578	X1578	
35096	35096	

1. ALL DIMENSIONS ARE IN mm.
2. ROUND OFF ALL SHARP CORNERS WITH 0.40 mm.
3. TOLERANCES WILL BE AS PER IS:3965-1981, UNLESS OTHERWISE SPECIFIED

PARTY'S NAME	PREMIER METAL CORPORATION, NEW DELHI
PARTY'S DRAWING No.	AS PER DRAWING
ALLOY & TEMPER	HE9 WP
DESCRIPTION	DISPLAY SECTION