

P-15600

35099

EXPOSED SURFACE

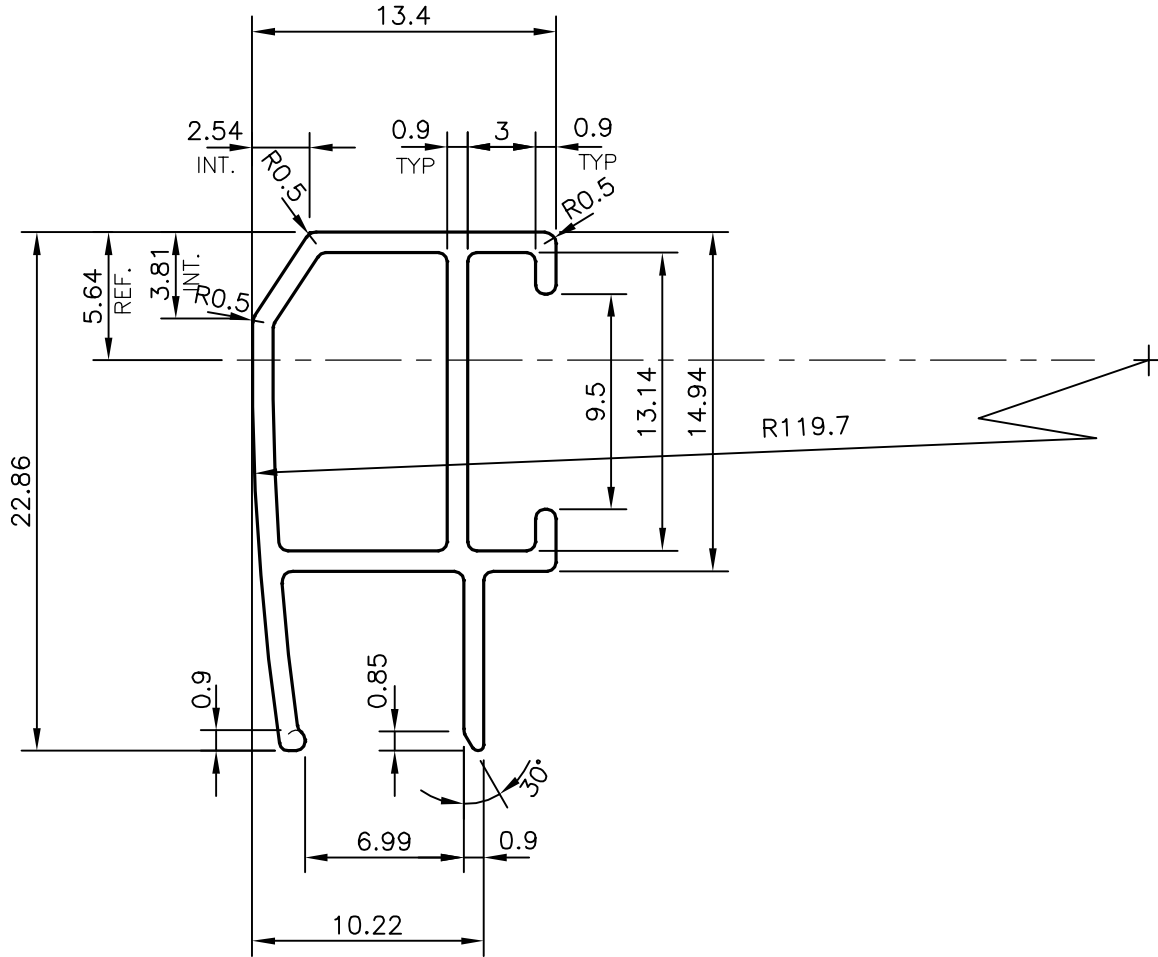
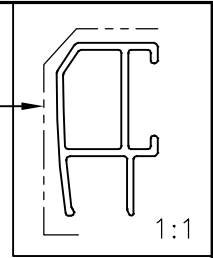

SYMBOL OF QUALITY
AN ISO 9001 COMPANY

JINDAL ALUMINIUM LTD.
BANGALORE-560073 (INDIA)

	NAME	DATE
DRAWN	J.P.KAUSHIK	12-02-2016
CHECKED		
APPROVED	B. NATARAJ	25-03-2016
SCALE		3:1
AREA mm ²		63.632
PERIMETER mm.		98.48
WEIGHT kg/m		0.172
DRAWING No.	SECTION No.	

1. ALL DIMENSIONS ARE IN mm.
2. ROUND OFF ALL SHARP CORNERS WITH 0.40 mm.
3. TOLERANCES WILL BE AS PER BS:EN-755-9 UNLESS OTHERWISE SPECIFIED

PARTY'S NAME	ACCO BRANDS CORPORATION, U.S.A
PARTY'S DRAWING No.	200-1199
ALLOY & TEMPER	6063 T52
DESCRIPTION	MISC. SECTION

P-15600	-
35099	35099