

P-13866

S4204

35109

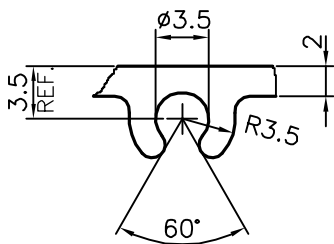
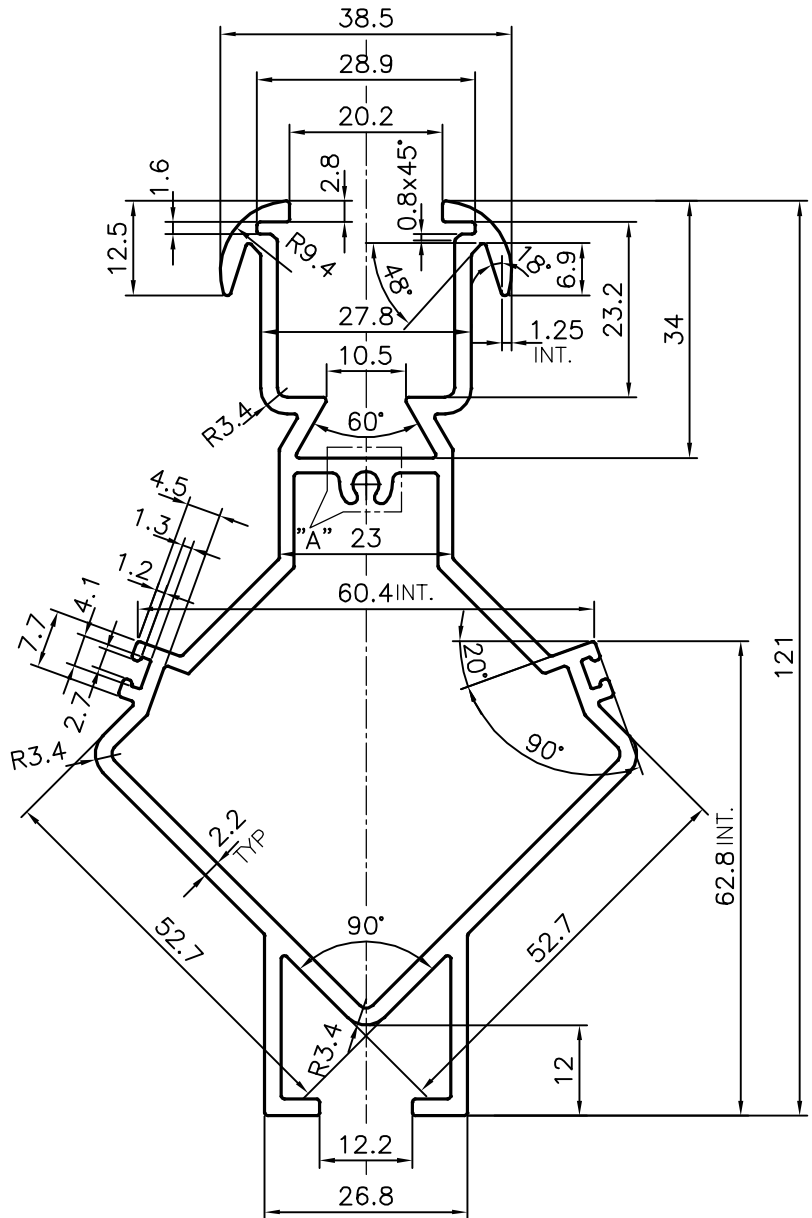
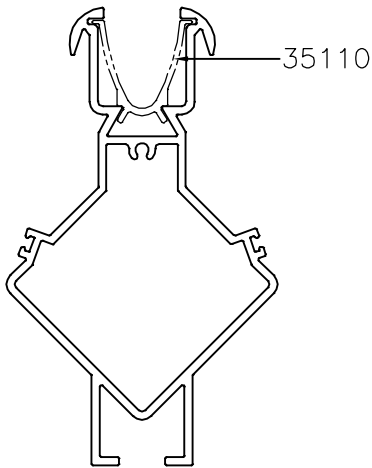

DETAIL OF "A"
SCALE 2:1



SYMBOL OF QUALITY
AN ISO 9001 COMPANY

JINDAL ALUMINIUM LTD.
BANGALORE-560073 (INDIA)

	NAME	DATE
DRAWN	J.P.KAUSHIK	11-08-2014
CHECKED		
APPROVED	S.S.GARG	14-08-2014
SCALE		1:1
AREA mm ²		863.509
PERIMETER mm.		563.978
WEIGHT kg/m		2.331
DRAWING No.	SECTION No.	
P-13866	-	
S4204	S4204	
35109	35109	

1. ALL DIMENSIONS ARE IN mm.
2. ROUND OFF ALL SHARP CORNERS WITH 0.40 mm.
3. TOLERANCES WILL BE AS PER IS:6477-1983 , UNLESS OTHERWISE SPECIFIED

PARTY'S NAME	IN'S & OUT, KOLKATA
PARTY'S DRAWING No.	AS PER DRAWING
ALLOY & TEMPER	HE9 WP
DESCRIPTION	MISC. SECTION