

P-13867

S4205

35110

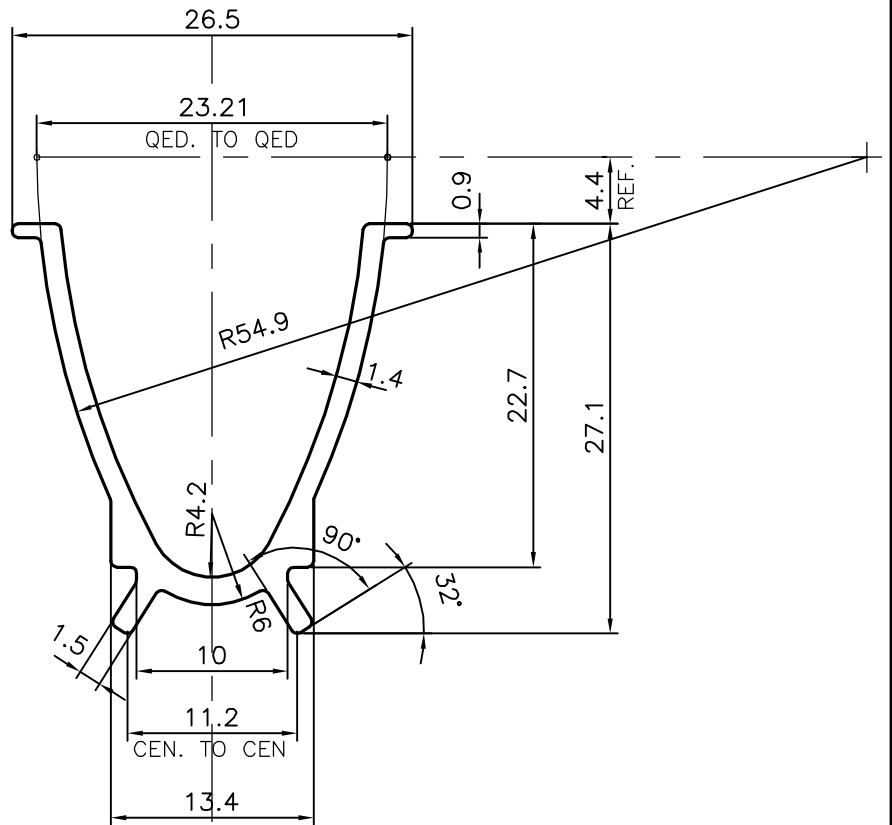
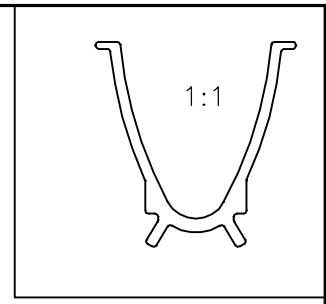
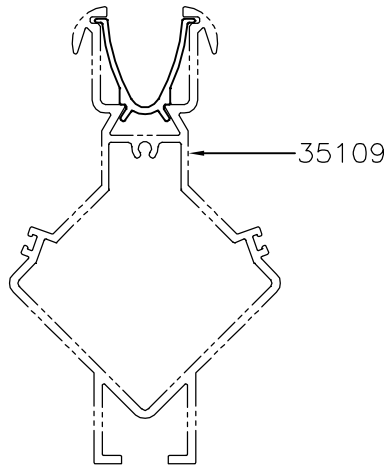

SYMBOL OF QUALITY
AN ISO 9001 COMPANY

JINDAL ALUMINIUM LTD.
BANGALORE-560073 (INDIA)

	NAME	DATE
DRAWN	J.P.KAUSHIK	11-08-2014
CHECKED		
APPROVED	S.S.GARG	14-08-2014
SCALE		2:1
AREA mm ²		107.119
PERIMETER mm.		137.46
WEIGHT kg/m		0.289
DRAWING No.	SECTION No.	
P-13867	-	
S4205	S4205	
35110	35110	

1. ALL DIMENSIONS ARE IN mm.
2. ROUND OFF ALL SHARP CORNERS WITH 0.40 mm.
3. TOLERANCES WILL BE AS PER IS:3965-1981 , UNLESS OTHERWISE SPECIFIED

PARTY'S NAME	IN'S & OUT, KOLKATA
PARTY'S DRAWING No.	AS PER DRAWING
ALLOY & TEMPER	HE9 WP
DESCRIPTION	MISC. SECTION