

P-15115
S4692
35128

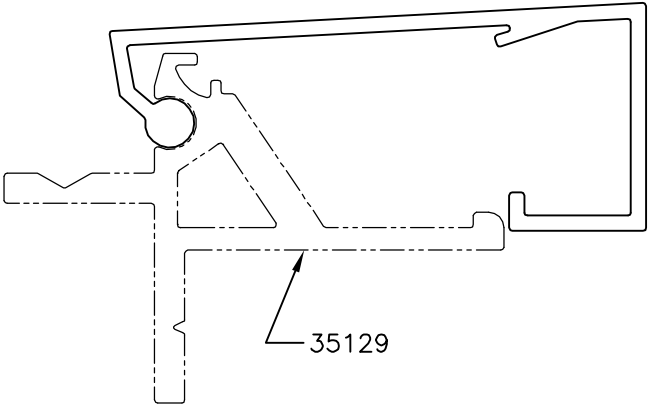
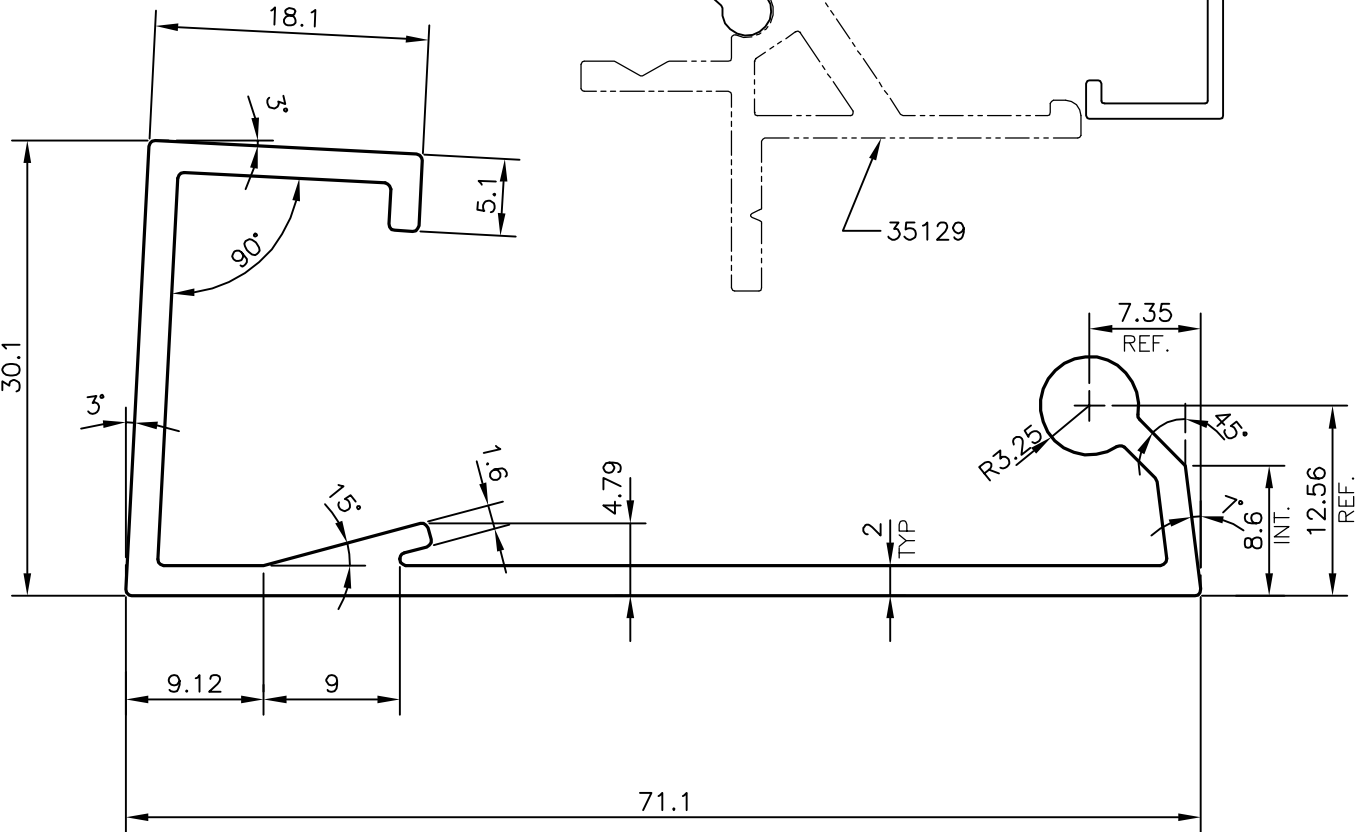
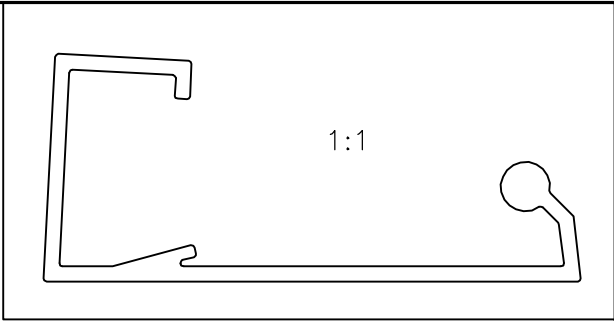

JINDAL ALUMINIUM LTD.
 BANGALORE-560073 (INDIA)

	NAME	DATE
DRAWN	J.P.KAUSHIK	02-09-2015
CHECKED		
APPROVED	S.S.GARG	25-09-2015
SCALE		2:1
AREA mm ²		303.852
PERIMETER mm.		281.27
WEIGHT kg/m		0.820
DRAWING No.	SECTION No.	
P-15115	-	
S4692	S4692	
35128	35128	

1. ALL DIMENSIONS ARE IN mm.
2. ROUND OFF ALL SHARP CORNERS WITH 0.40 mm.
3. TOLERANCES WILL BE AS PER IS:3965-1981 , UNLESS OTHERWISE SPECIFIED

PARTY'S NAME	ELECTROSPARK, GURGAON
PARTY'S DRAWING No.	AS PER AutoCAD DRAWING
ALLOY & TEMPER	6063 T6
DESCRIPTION	MISC. SECTION