

P-15118

S4695

35131

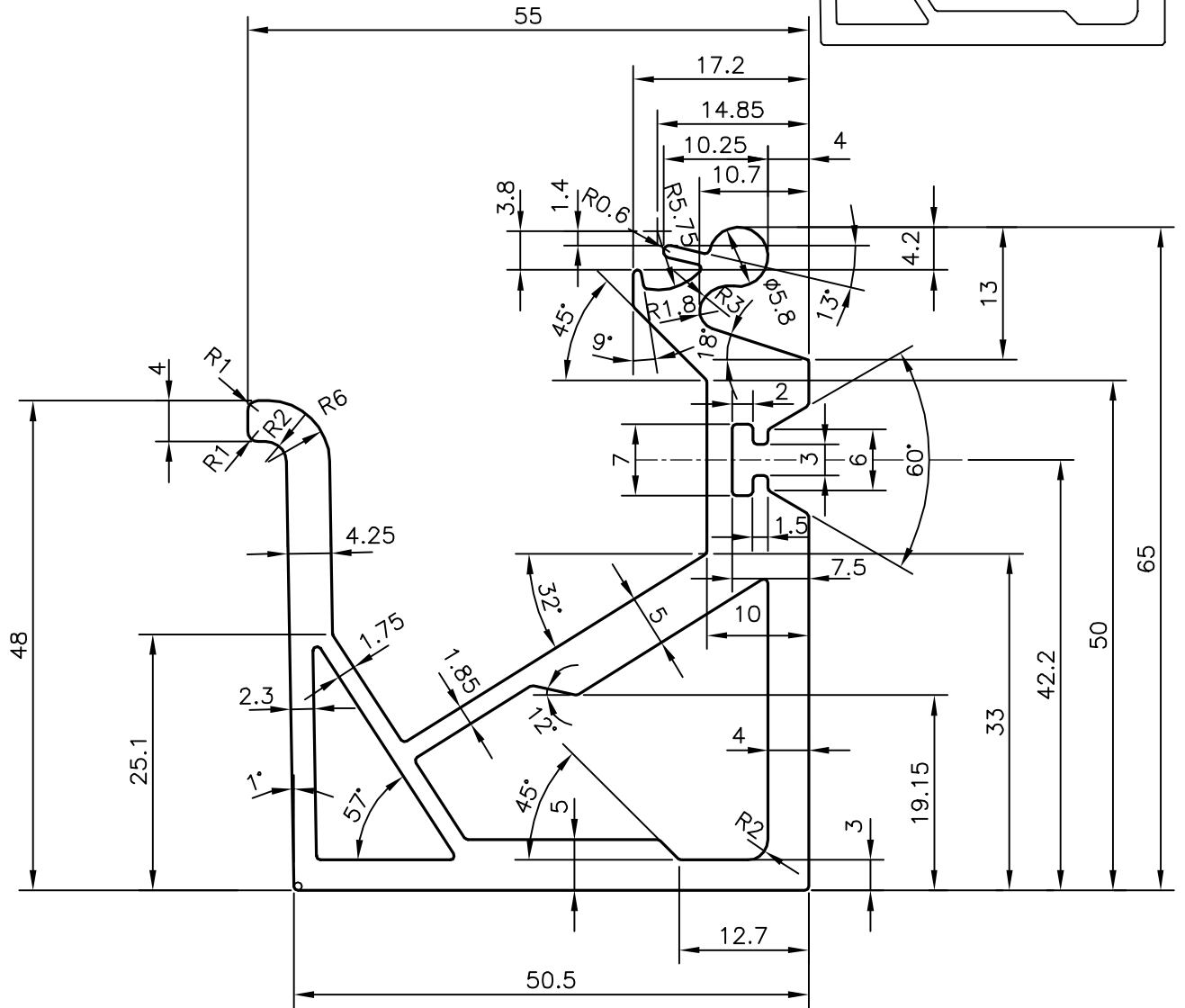
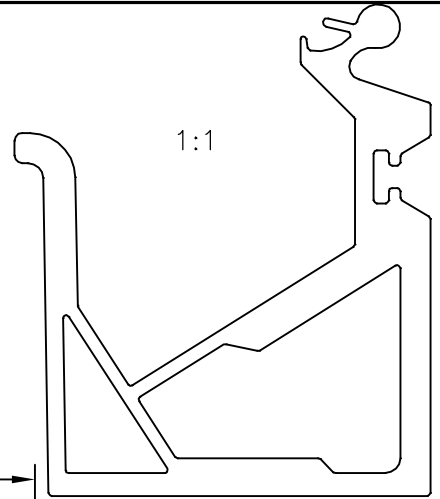
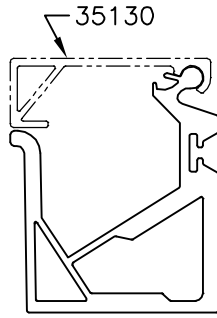

SYMBOL OF QUALITY
AN ISO 9001 COMPANY

JINDAL ALUMINIUM LTD.
BANGALORE-560073 (INDIA)

	NAME	DATE
DRAWN	J.P.KAUSHIK	02-09-2015
CHECKED		
APPROVED	S.S.GARG	25-09-2015
SCALE		1.5:1
AREA mm ²		888.042
PERIMETER mm.		325.26
WEIGHT kg/m		2.398
DRAWING No.	SECTION No.	
P-15118	-	
S4695	S4695	
35131	35131	

1. ALL DIMENSIONS ARE IN mm.
2. ROUND OFF ALL SHARP CORNERS WITH 0.40 mm.
3. TOLERANCES WILL BE AS PER IS:6477-1983 , UNLESS OTHERWISE SPECIFIED

PARTY'S NAME	ELECTROSPARK, GURGAON
PARTY'S DRAWING No.	AS PER AutoCAD DRAWING
ALLOY & TEMPER	6063 T6
DESCRIPTION	MISC. SECTION