

P-15178

S4684

35132

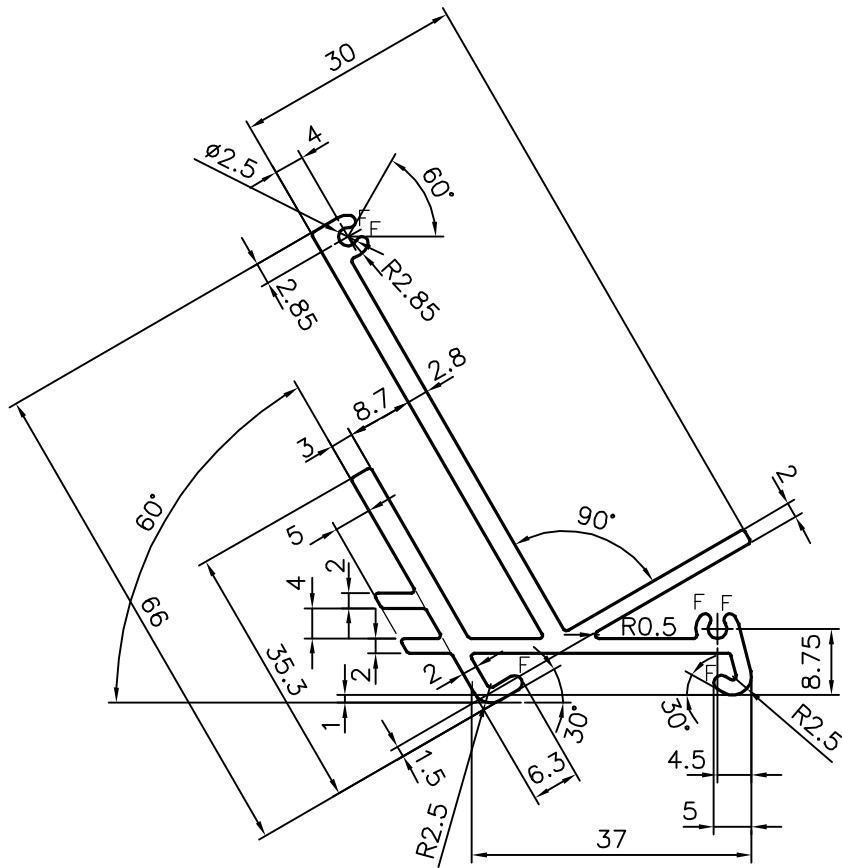

F = FULL RADIUS(6 PLACES)



SYMBOL OF QUALITY
AN ISO 9001 COMPANY

JINDAL ALUMINIUM LTD.
BANGALORE-560073 (INDIA)

	NAME	DATE
DRAWN	J.P.KAUSHIK	15-09-2015
CHECKED		
APPROVED	S.S.GARG	23-09-2015
SCALE		1:1
AREA mm ²		467.804
PERIMETER mm.		384.665
WEIGHT kg/m		1.263
DRAWING No.	SECTION No.	
P-15178	-	
S4684	S4684	
35132	35132	

1. ALL DIMENSIONS ARE IN mm.
2. ROUND OFF ALL SHARP CORNERS WITH 0.40 mm.
3. TOLERANCES WILL BE AS PER IS:3965-1981, UNLESS OTHERWISE SPECIFIED

PARTY'S NAME	PRESTAIR SYSTEMS, NOIDA
PARTY'S DRAWING No.	AS PER SAMPLE
ALLOY & TEMPER	6063 T6
DESCRIPTION	MISC. SECTION