

P-15384-1

S4755

35137

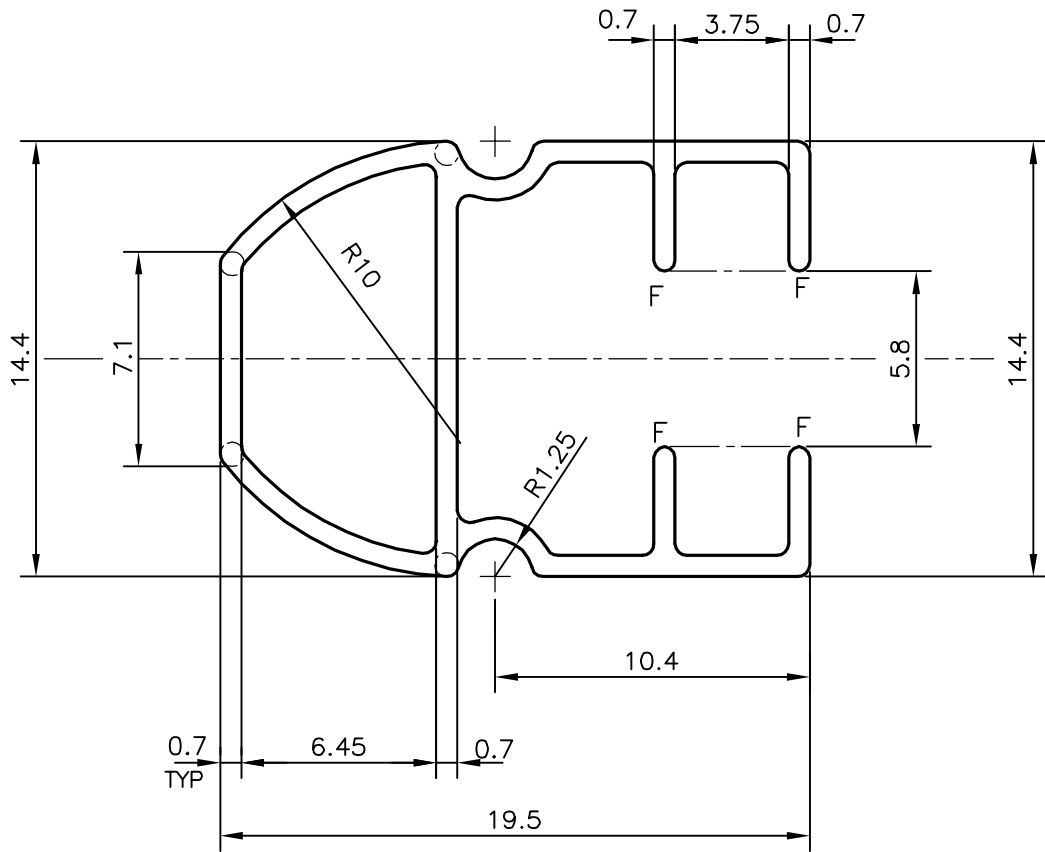

F = FULL RADIUS (4 PLACES)



SYMBOL OF QUALITY
AN ISO 9001 COMPANY

JINDAL ALUMINIUM LTD.
BANGALORE-560073 (INDIA)

	NAME	DATE
DRAWN	J.P.KAUSHIK	02-12-2015
CHECKED		
APPROVED	S.S.GARG	07-12-2015
SCALE		4:1
AREA mm ²		53.324
PERIMETER mm.		112.75
WEIGHT kg/m		0.144

1. ALL DIMENSIONS ARE IN mm.
2. ROUND OFF ALL SHARP CORNERS WITH 0.40 mm.
3. TOLERANCES WILL BE AS PER IS:6477-1983 UNLESS OTHERWISE SPECIFIED

PARTY'S NAME	HINDAUN SLATE PRODUCTS (I), KAROLI (RAJ.)	DRAWING No.	P-15384-1	SECTION No.	-
PARTY'S DRAWING No.	AS PER SAMPLE & REQUIREMENT	S4755	S4755		
ALLOY & TEMPER	HE9 WP	35137	35137		
DESCRIPTION	DISPLAY SECTION				