

P-15393

X1957

35139

EXPOSED SURFACE

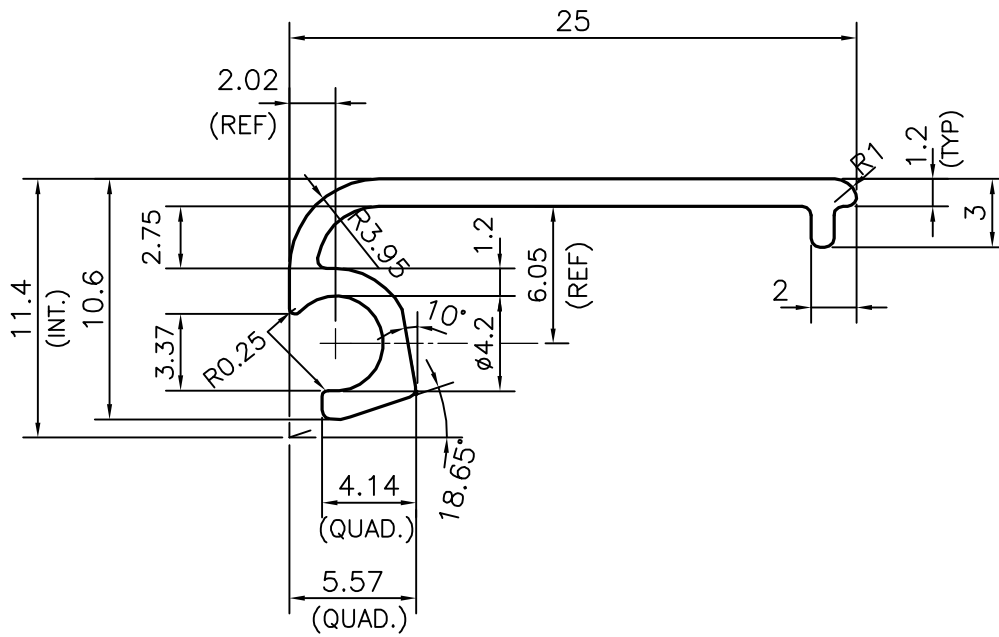
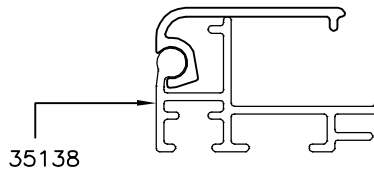
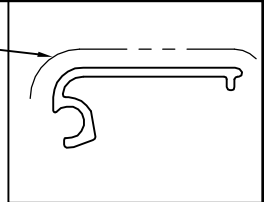

SYMBOL OF QUALITY  
AN ISO 9001 COMPANY

**JINDAL ALUMINIUM LTD.**  
BANGALORE-560073 (INDIA)

	NAME	DATE
DRAWN	J.P.KAUSHIK	05-12-2015
CHECKED		
APPROVED	S.S.GARG	08-01-2016
SCALE		3:1
AREA mm <sup>2</sup>		48.27
PERIMETER mm.		80.787
WEIGHT kg/m		0.130
DRAWING No.	SECTION No.	
P-15393	-	
X1957	X1957	
35139	35139	

1. ALL DIMENSIONS ARE IN mm.
2. ROUND OFF ALL SHARP CORNERS WITH 0.40 mm.
3. TOLERANCES WILL BE AS PER IS:3965-1981, UNLESS OTHERWISE SPECIFIED

PARTY'S NAME	ELCARE SYSTEMS PVT. LTD., COCHIN
PARTY'S DRAWING No.	AS PER SAMPLE
ALLOY & TEMPER	HE9 WP
DESCRIPTION	DISPLAY SECTION