

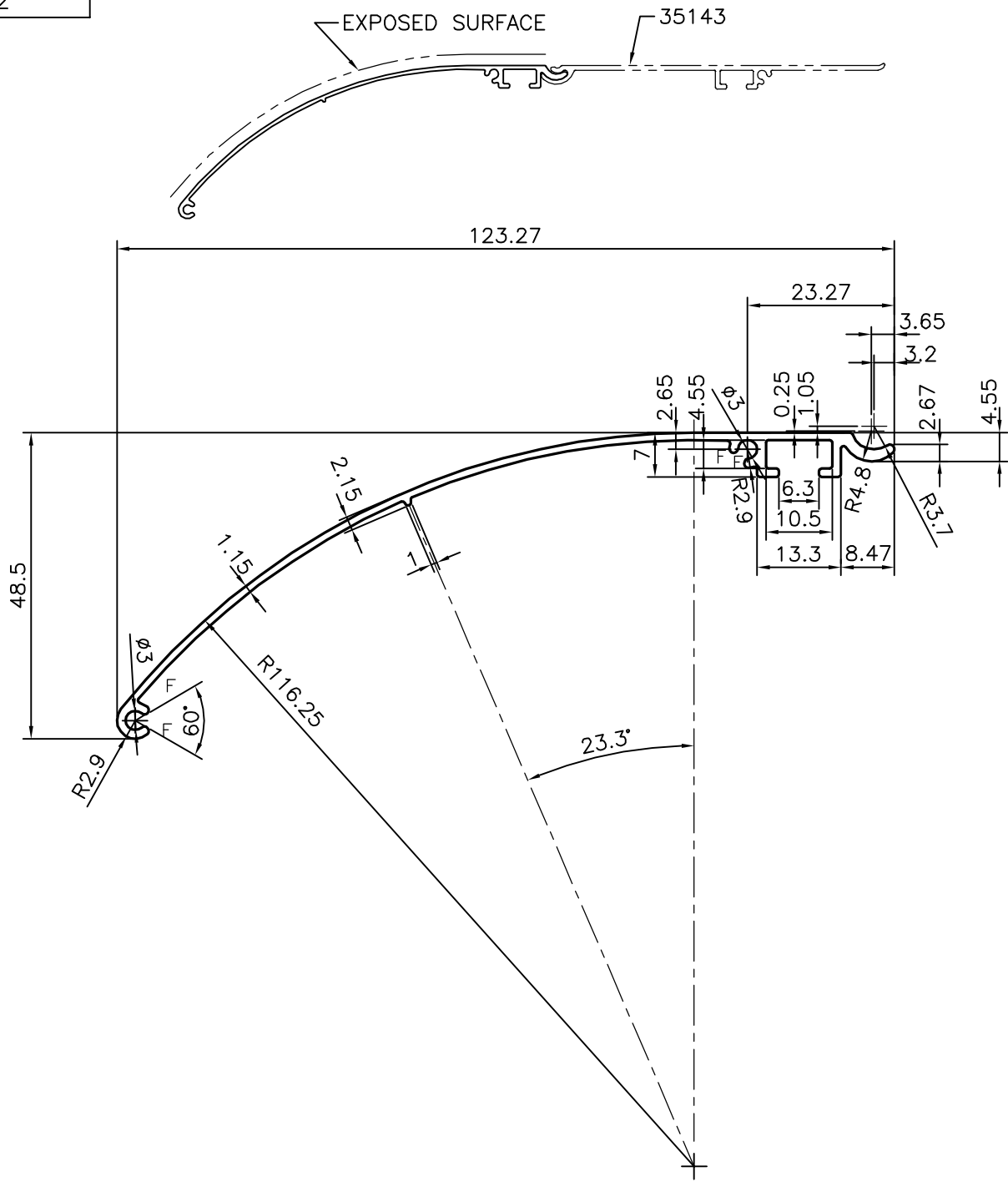

P-15625
S4867
35142



F= FULL RADIUS(4 PLACES)

 SYMBOL OF QUALITY AN ISO 9001 COMPANY	JINDAL ALUMINIUM LTD. BANGALORE-560073 (INDIA)	NAME		DATE
		DRAWN	J.P.KAUSHIK	24-02-2016
1. ALL DIMENSIONS ARE IN mm. 2. ROUND OFF ALL SHARP CORNERS WITH 0.4 mm. 3. TOLERANCES WILL BE AS PER IS:3965-1981, UNLESS OTHERWISE SPECIFIED		CHECKED		
		APPROVED	S.S.GARG	27-03-2016
PARTY'S NAME		SCALE		1:1
		AREA mm ²		207.633
PARTY'S DRAWING No.		PERIMETER mm.		328.758
		WEIGHT kg/m		0.561
ALLOY & TEMPER		DRAWING No.	SECTION No.	
		P-15625	-	
DESCRIPTION		S4867	S4867	
		35142	35142	
MISC. SECTION				