

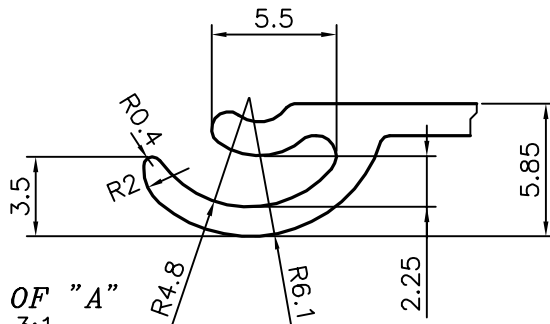

P-15626
S4868
35143

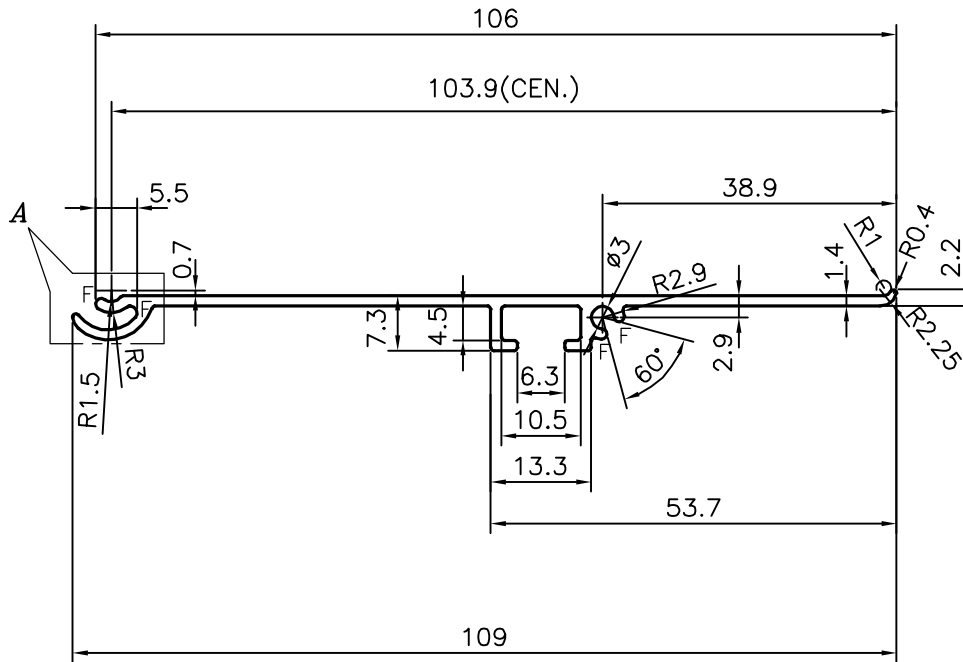
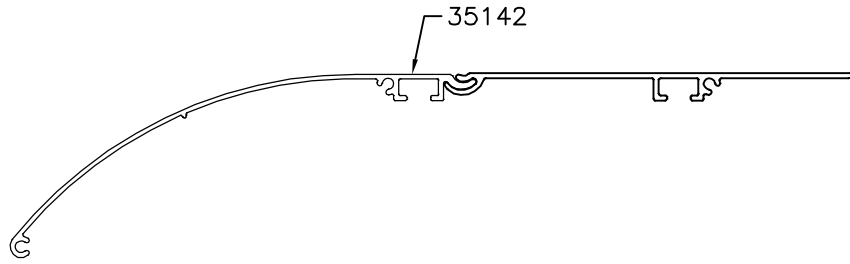

DETAIL OF "A"
SCALE 3:1

F= FULL RADIUS(4 PLACES)

 SYMBOL OF QUALITY AN ISO 9001 COMPANY	JINDAL ALUMINIUM LTD. BANGALORE-560073 (INDIA)	NAME	DATE
		DRAWN	J.P.KAUSHIK 24-02-2016
		CHECKED	
		APPROVED	S.S.GARG 27-03-2016
		SCALE	1:1
		AREA mm ²	194.236
		PERIMETER mm.	273.094
		WEIGHT kg/m	0.524
PARTY'S NAME	MAC LIFESTYLE PRODUCT PVT. LTD., NEW DELHI	DRAWING No.	SECTION No.
PARTY'S DRAWING No.	AS PER SAMPLE	P-15626	-
ALLOY & TEMPER	6063 T6	S4868	S4868
DESCRIPTION	MISC. SECTION	35143	35143