

P-16539

S5184

35158

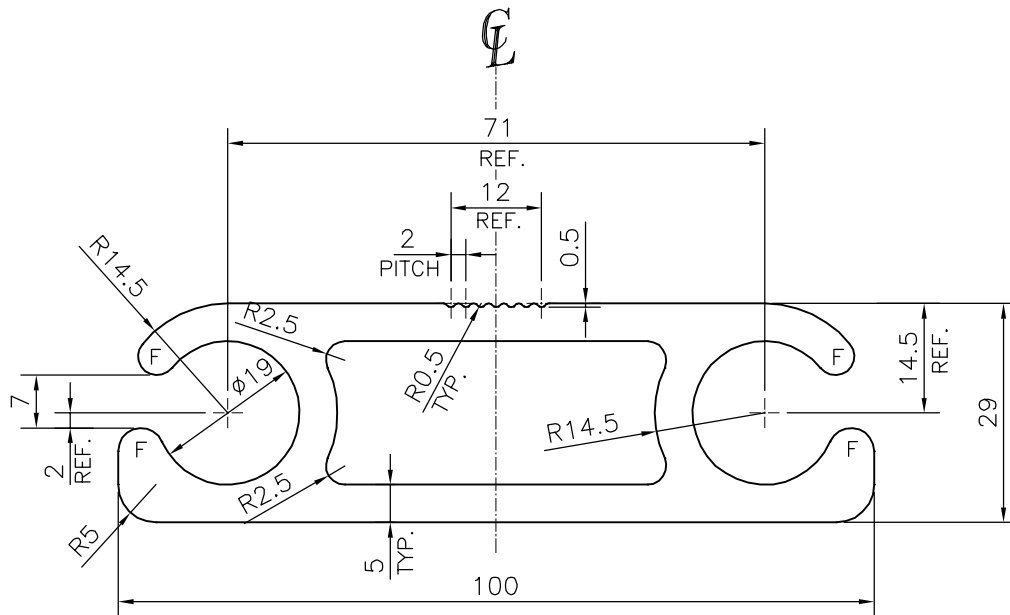

F = FULL RADIUS (4 PLACES)



SYMBOL OF QUALITY
AN ISO 9001 COMPANY

JINDAL ALUMINIUM LTD.
BANGALORE-560073 (INDIA)

	NAME	DATE
DRAWN	PARVESH	18-11-2016
CHECKED		
APPROVED	B.NATARAJA	22-11-2016
SCALE		1:1
AREA mm ²		1317.576
PERIMETER mm.		344.571
WEIGHT kg/m		3.557
DRAWING No.	SECTION No.	
P-16539	-	
S5184	S5184	
35158	35158	

1. ALL DIMENSIONS ARE IN mm.
2. ROUND OFF ALL SHARP CORNERS WITH 0.50 mm.
3. TOLERANCES WILL BE AS PER IS:6477-1983 , UNLESS OTHERWISE SPECIFIED

PARTY'S NAME	SREE BHARAT KIRAYA BHANDAR, RAIPUR
PARTY'S DRAWING No.	AS PER DRAWING
ALLOY & TEMPER	6005 T6
DESCRIPTION	DISPLAY SECTION