

P-16538

S5183

35159

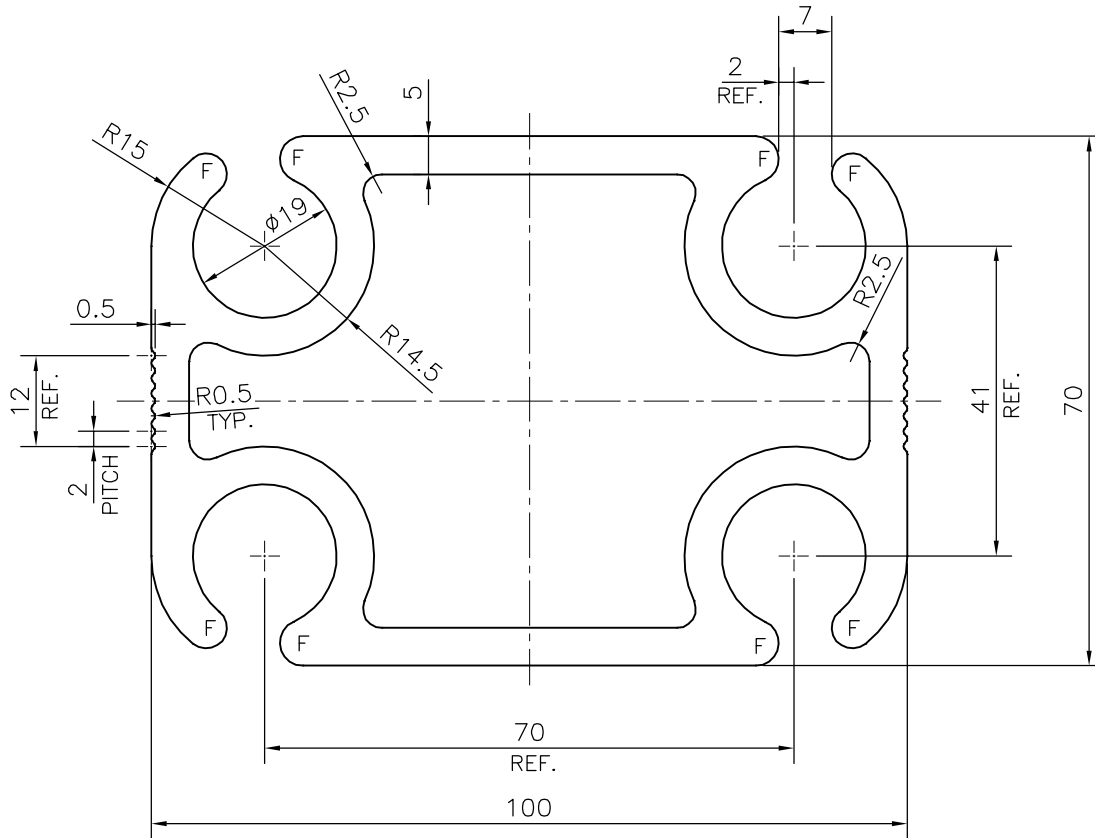

F = FULL RADIUS (8 PLACES)



SYMBOL OF QUALITY  
AN ISO 9001 COMPANY

**JINDAL ALUMINIUM LTD.**  
BANGALORE-560073 (INDIA)

	NAME	DATE
DRAWN	PARVESH	18-11-2016
CHECKED		
APPROVED	B.NATARAJA	22-11-2016
SCALE		1:1
AREA mm <sup>2</sup>		2221.013
PERIMETER mm.		523.693
WEIGHT kg/m		5.997
DRAWING No.	SECTION No.	
P-16538	-	
S5183	S5183	
35159	35159	

1. ALL DIMENSIONS ARE IN mm.
2. ROUND OFF ALL SHARP CORNERS WITH 0.50 mm.
3. TOLERANCES WILL BE AS PER IS:6477-1983 , UNLESS OTHERWISE SPECIFIED

PARTY'S NAME	SREE BHARAT KIRAYA BHANDAR, RAIPUR
PARTY'S DRAWING No.	AS PER DRAWING
ALLOY & TEMPER	6005 T6
DESCRIPTION	DISPLAY SECTION