

IAL-D-5267

35183

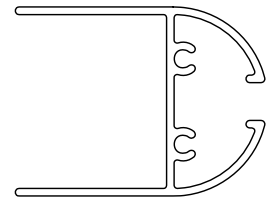

SCALE 1:1

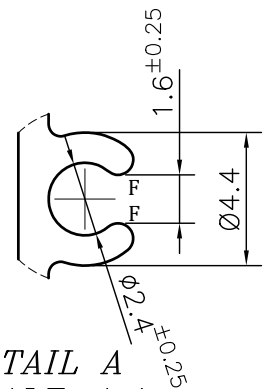
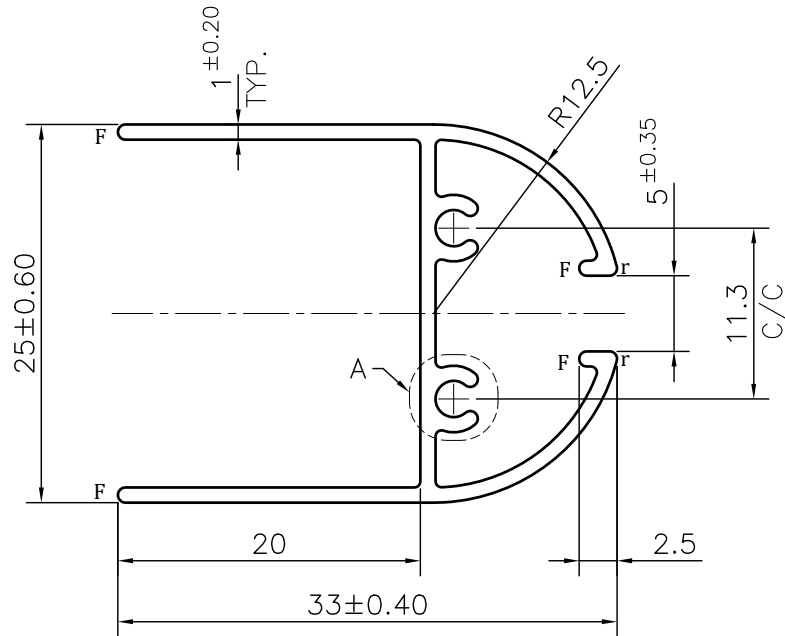

DETAIL A
SCALE 4:1

NOTE:-

r= 0.50 RADIUS (2 PLACES)
F= FULL RADIUS (8 PLACES)

1. STRAIGHTNESS= 1.7mm/M
2. TWIST= 1.7mm/M
3. ANGULARITY= ±2°
4. FLATNESS= 0.007xWIDTH



SYMBOL OF QUALITY
AN ISO 9001 COMPANY

JINDAL ALUMINIUM LTD.
BHIWADI-301019 (INDIA)

	NAME	DATE
DRAWN	ASHUTOSH	07-02-2024
CHECKED		
APPROVED		

1. ALL DIMENSIONS ARE IN mm.
2. ROUND OFF ALL SHARP CORNERS WITH 0.40 mm.
3. TOLERANCES WILL BE AS PER BS:EN-755-9 , UNLESS OTHERWISE SPECIFIED

PARTY'S NAME	JOHNSON
--------------	---------

PARTY'S DRAWING No.	AS PER DRAWING
---------------------	----------------

ALLOY & TEMPER	6063 T6	PRODUCT CODE:-049
		HSN CODE:- 76042990

DESCRIPTION	VENETIAN BLIND SECTION
-------------	------------------------