

P-7084

S1952

35532

DETAIL "A"  
SCALE 3:1

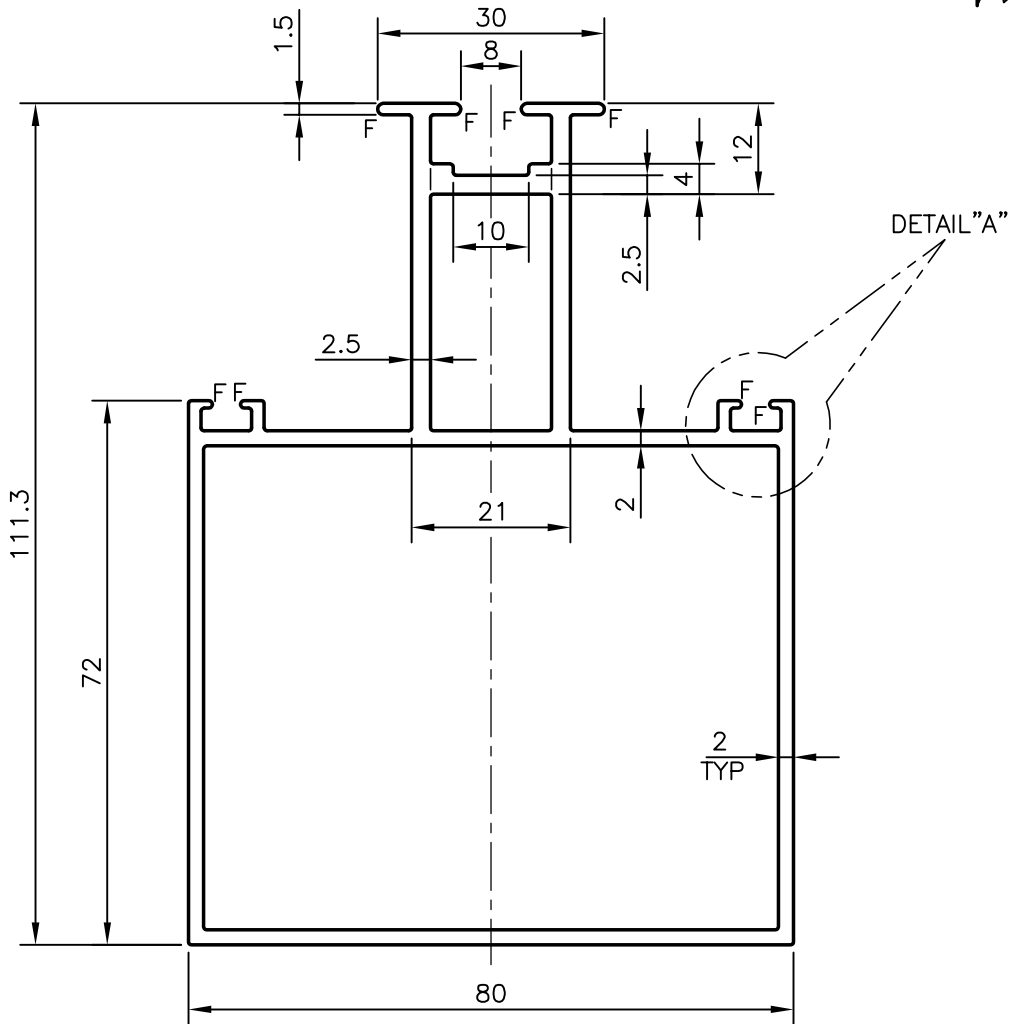
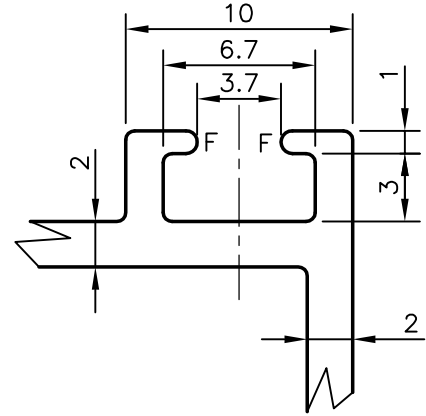

TWIST = 1.70mm/MTR.LENGTH  
 FLATNESS = ±0.75mm  
 ANGULARITY = ±2  
 STRAIGHTNESS = 1.5mm/MTR.LENGTH

GENERAL WALL THICKNESS = 2.00mm  
 F = FULL RADIUS (8 PLACES)



SYMBOL OF QUALITY  
 AN ISO 9001 COMPANY

**JINDAL ALUMINIUM LTD.**  
 BANGALORE-560073 (INDIA)

	NAME	DATE
DRAWN	RAGHAVENDRA	01-03-2007
CHECKED		
APPROVED		
SCALE		1:1
AREA mm <sup>2</sup>		898.693
PERIMETER mm.		470.503
WEIGHT kg/m		2.426
DRAWING No.	SECTION No.	
P-7084	-	
S1952	S1952	
35532	35532	

- ALL DIMENSIONS ARE IN mm.
- ROUND OFF ALL SHARP CORNERS WITH 0.40 mm.
- TOLERANCES WILL BE AS PER IS:6477-1983 UNLESS OTHERWISE SPECIFIED

PARTY'S NAME	EMAR ENTERPRISES, BANGALORE
PARTY'S DRAWING No.	AS PER DRAWING
ALLOY & TEMPER	HE9 WP
DESCRIPTION	CURTAIN WALL SECTION