

P-9130-3

S2119

35536

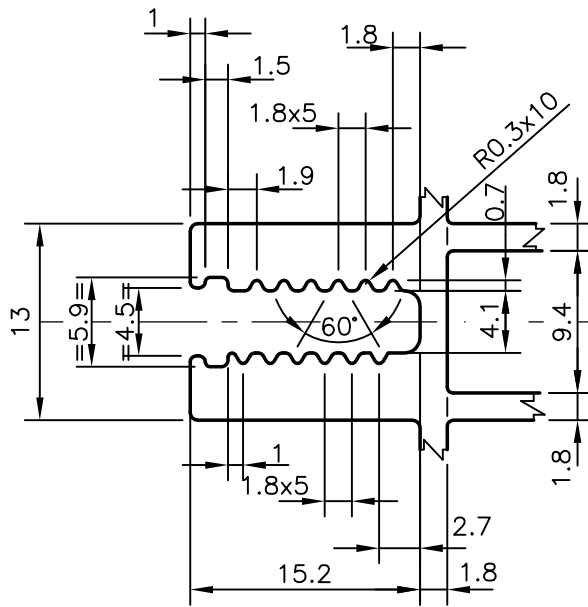

DETAIL OF "A"

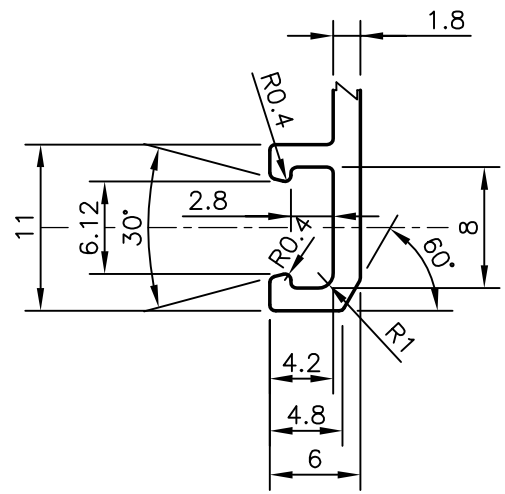

DETAIL OF "B"

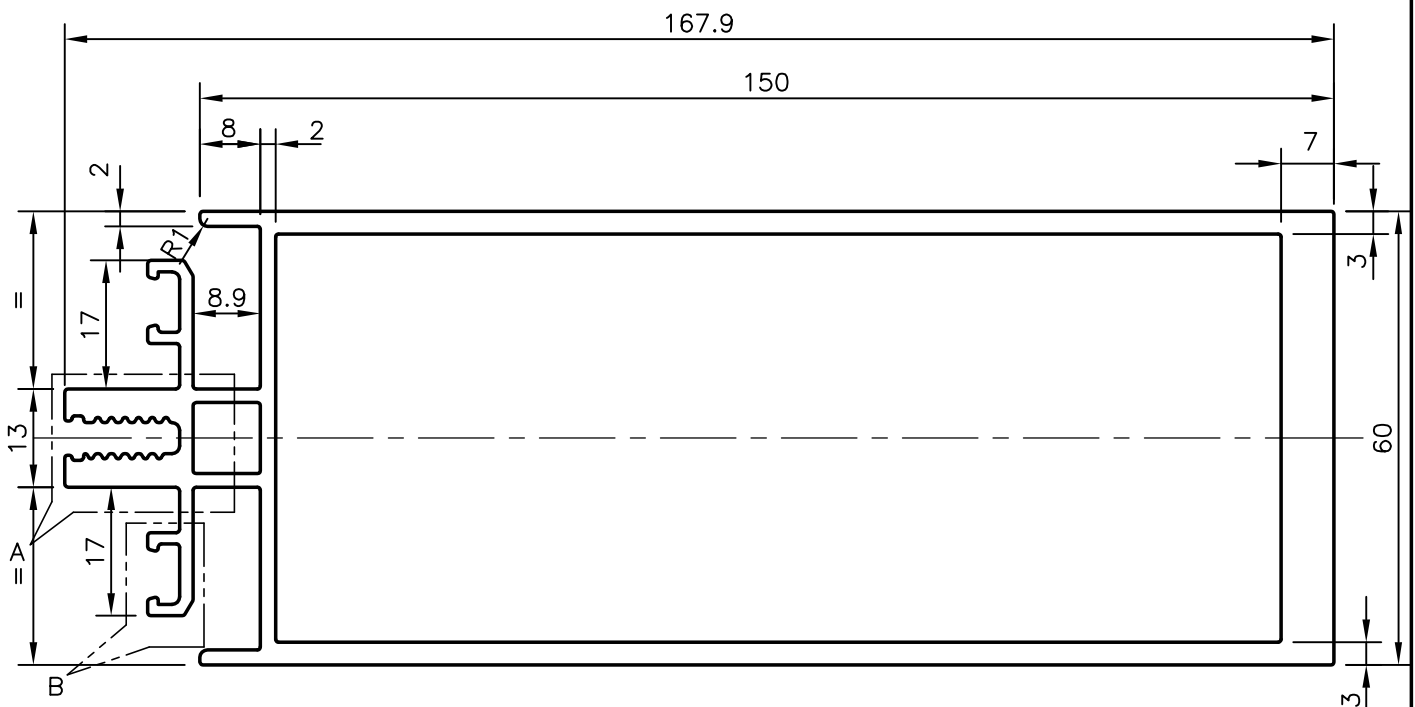

SYMBOL OF QUALITY
AN ISO 9002 COMPANY

JINDAL ALUMINIUM LTD.
BANGALORE-560073 (INDIA)

	NAME	DATE
DRAWN	J.P.KAUSHIK	25-04-2009

CHECKED		
APPROVED		

SCALE	1:1
AREA mm ²	1640.447
PERIMETER mm.	625.796
WEIGHT kg/m	4.429

DRAWING No.	SECTION No.
P-9130-3	-
S2119	S2119
35536	35536

1. ALL DIMENSIONS ARE IN mm.
2. ROUND OFF ALL SHARP CORNERS WITH 0.40 mm.
3. TOLERANCES WILL BE AS PER IS:6477-1983 UNLESS OTHERWISE SPECIFIED

PARTY'S NAME SP FABRICATORS (P) LTD., THANE

PARTY'S DRAWING No. AL- 542 REV. 0

ALLOY & TEMPER 6063 T6

DESCRIPTION CURTAIN WALL MULLION PROFILE