

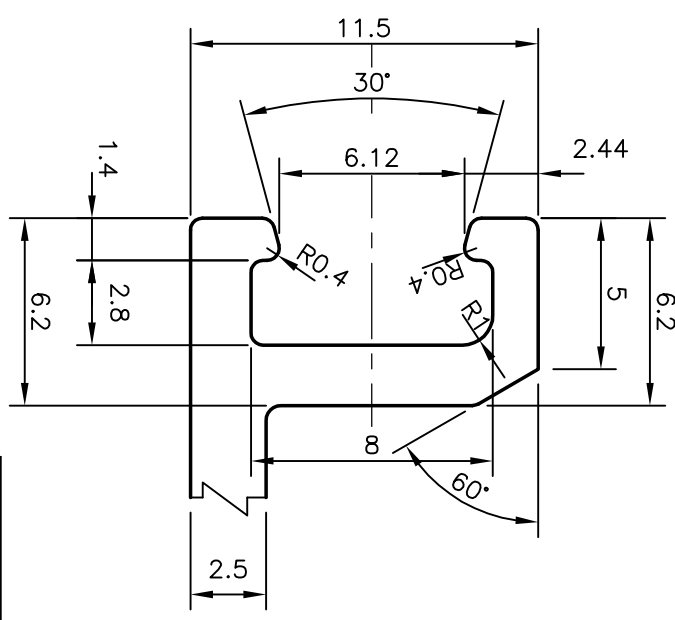

P-9131-3  
S2120  
35537

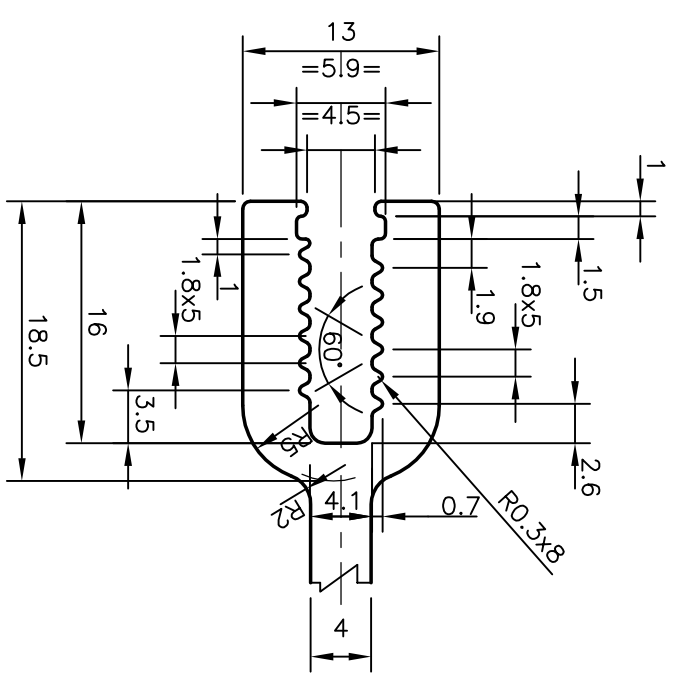
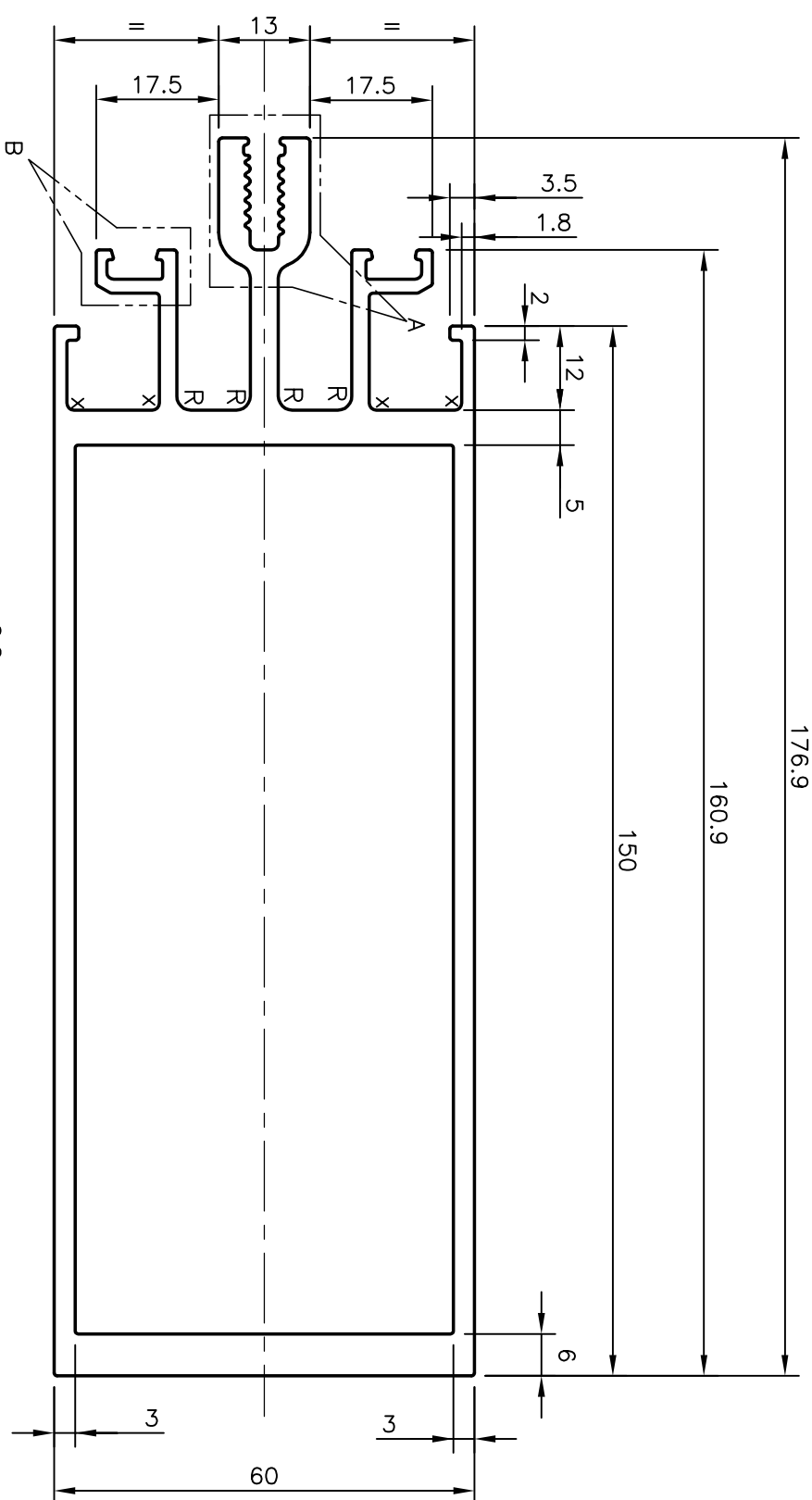

x = R 1.0 RADII ( 4 PLACES )  
R = R 2.0 RADII ( 4 PLACES )

DETAIL OF "A"

DETAIL OF "B"

 SYMBOL OF QUALITY AN ISO 9001 COMPANY		<b>JINDAL ALUMINIUM LTD.</b> BANGALORE-560073 (INDIA)		DRAWN	NAME	DATE
1. ALL DIMENSIONS ARE IN mm. 2. ROUND OFF ALL SHARP CORNERS WITH 0.40 mm. 3. TOLERANCES WILL BE AS PER IS:6477-1983 UNLESS OTHERWISE SPECIFIED				CHECKED	J.P. KAUSHIK	25-04-2009
PARTY'S NAME		SP FABRICATORS (P) LTD., MUMBAI		APPROVED		
PARTY'S DRAWING No.		AL-541		SCALE	1:1	
ALLOY & TEMPER		6063 T6		AREA mm <sup>2</sup>	1875.112	
DESCRIPTION		CURTAIN WALL MULLION PROFILE		PERIMETER mm.	719.663	
		WEIGHT kg/m		5.063		
		DRAWING No.		SECTION No.		
		P-9131-3		-		
		S2120		S2120		
		35537		35537		