

P-9486-1

S2279

35542

EXPOSED SURFACE

DETAIL OF "A"  
SCALE 3:1

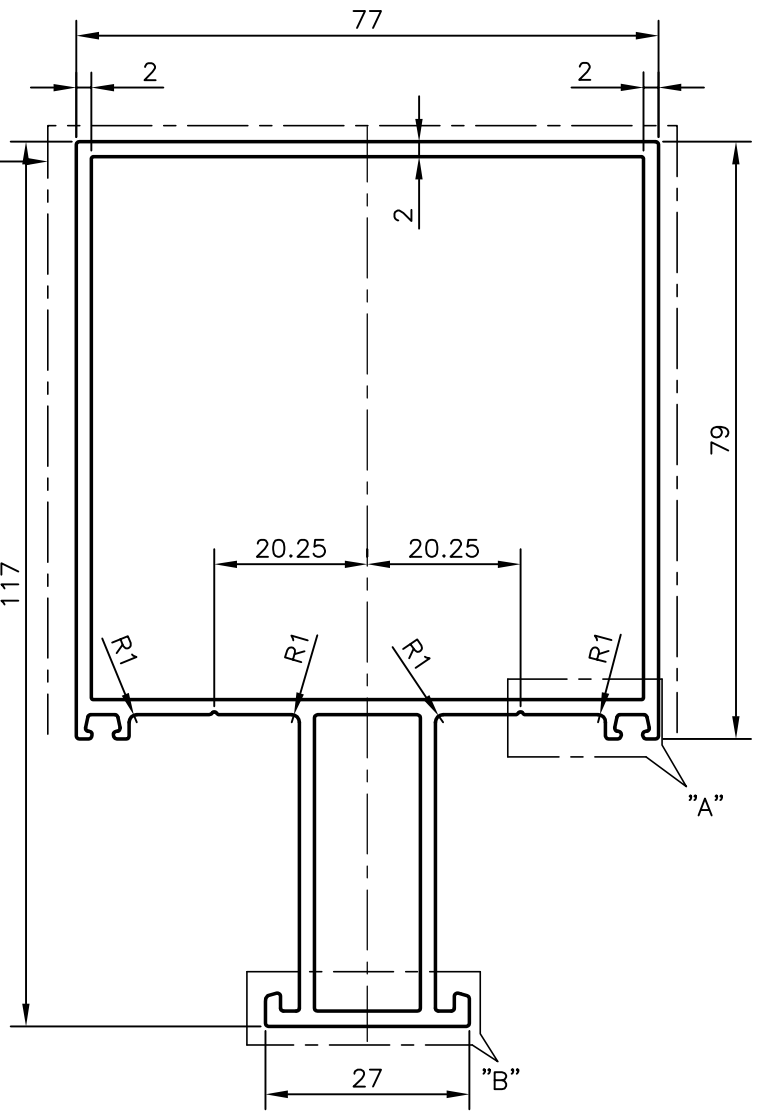
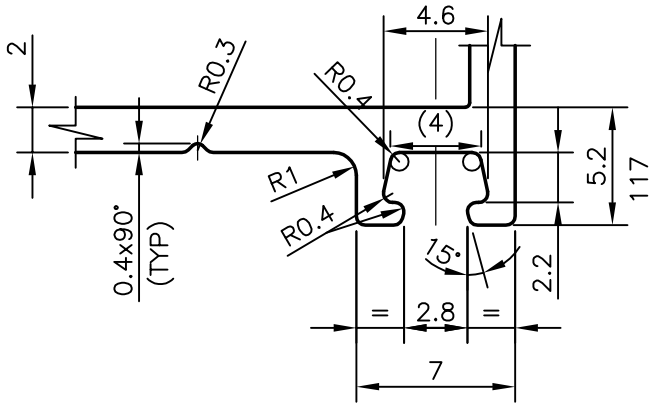

DETAIL OF "B"  
SCALE 3:1

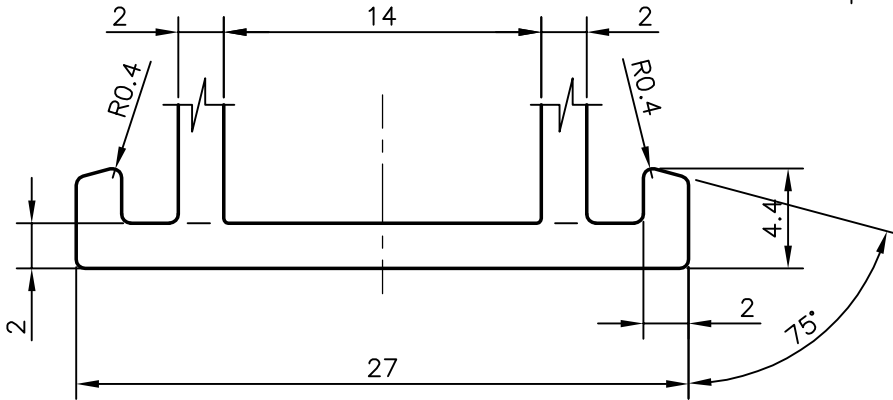

SYMBOL OF QUALITY  
AN ISO 9001 COMPANY

**JINDAL ALUMINIUM LTD.**  
BANGALORE-560073 (INDIA)

	NAME	DATE
DRAWN	J.P.KAUSHIK	19-09-2009
CHECKED		
APPROVED		

1. ALL DIMENSIONS ARE IN mm.
2. ROUND OFF ALL SHARP CORNERS WITH 0.40 mm.
3. TOLERANCES WILL BE AS PER IS:6477-1983 UNLESS OTHERWISE SPECIFIED

SCALE	1:1
AREA mm <sup>2</sup>	835.314
PERIMETER mm.	439.852
WEIGHT kg/m	2.255

PARTY'S NAME: SP FABRICATORS PVT. LTD., THANE

PARTY'S DRAWING No.: AL-583

ALLOY & TEMPER: 6063 T6

DESCRIPTION: CURTAIN WALL-TRANSOM SECTION

DRAWING No.	SECTION No.
P-9486-1	-
S2279	S2279
35542	35542