

P-9611-1

S2382

35546

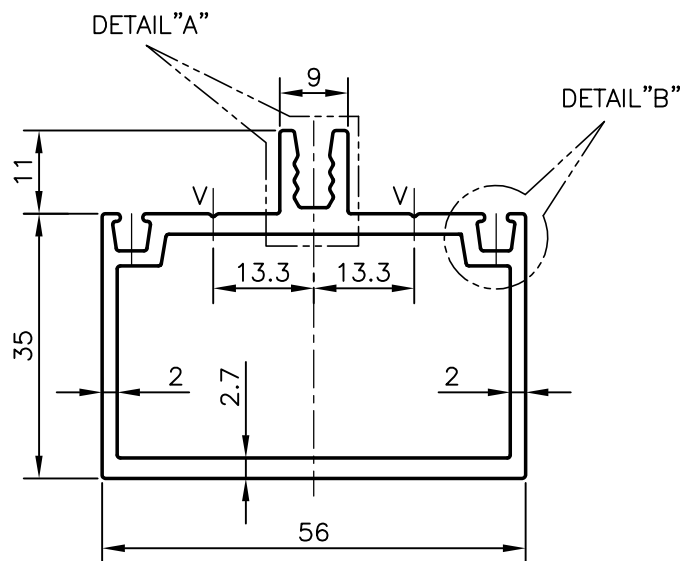
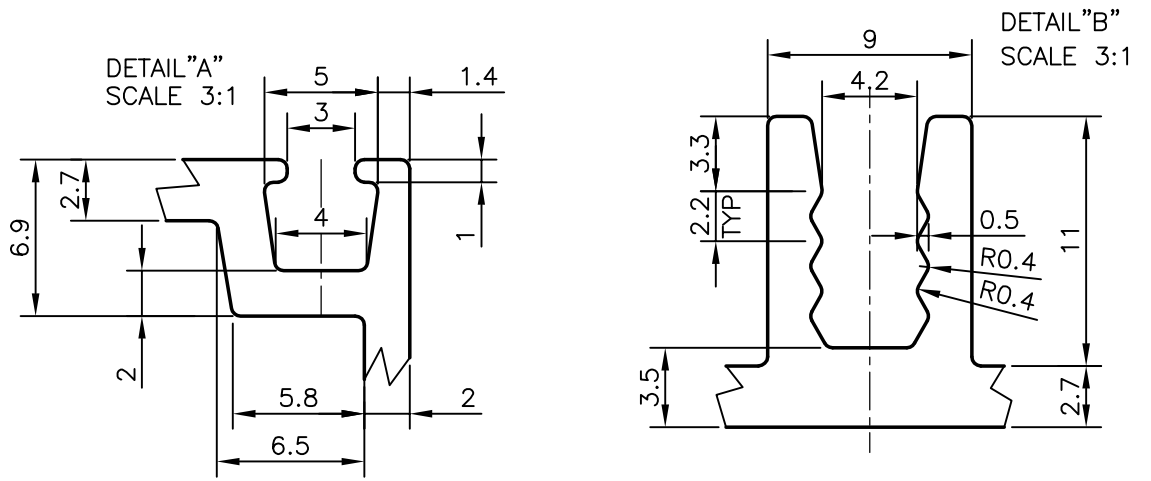

"V" = VEE GROOVE (0.40x90°) (2 PLACES)



SYMBOL OF QUALITY  
AN ISO 9001 COMPANY

**JINDAL ALUMINIUM LTD.**  
BANGALORE-560073 (INDIA)

	NAME	DATE
DRAWN	RAGHAVENDRA	10-11-2009
CHECKED		
APPROVED		

1. ALL DIMENSIONS ARE IN mm.
2. ROUND OFF ALL SHARP CORNERS WITH 0.40 mm.
3. TOLERANCES WILL BE AS PER IS:6477-1983, UNLESS OTHERWISE SPECIFIED

SCALE	1:1
AREA mm <sup>2</sup>	481.697
PERIMETER mm.	246.664
WEIGHT kg/m	1.301

PARTY'S NAME	S S FACADE PVT. LTD., GURGAON
PARTY'S DRAWING No.	AS PER DRAWING & AS PER REQUIREMENT
ALLOY & TEMPER	6063 T6
DESCRIPTION	TRANSOM SECTION

DRAWING No.	SECTION No.
P-9611-1	-
S2382	S2382
35546	35546