

P-9556

S2330

35549

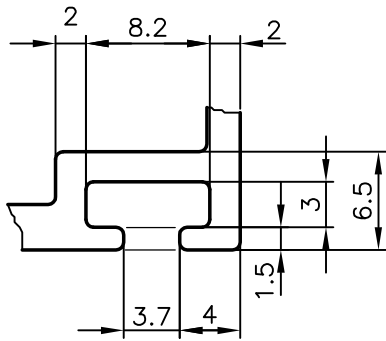
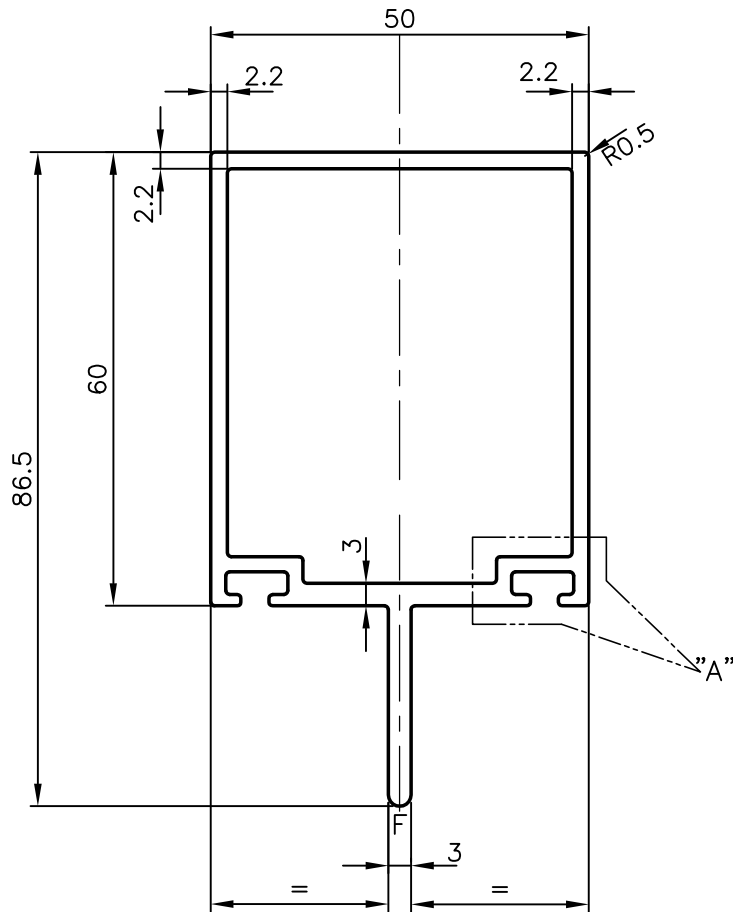

DETAIL OF "A"  
SCALE 2:1

UNSPECIFIED RADIUS 0.5 mm  
F= FULL RADIUS



SYMBOL OF QUALITY  
AN ISO 9001 COMPANY

**JINDAL ALUMINIUM LTD.**  
BANGALORE-560073 (INDIA)

	NAME	DATE
DRAWN	J.P.KAUSHIK	14-10-2009
CHECKED		
APPROVED		

1. ALL DIMENSIONS ARE IN mm.
2. ROUND OFF ALL SHARP CORNERS WITH 0.50 mm.
3. TOLERANCES WILL BE AS PER IS:6477-1983 UNLESS OTHERWISE SPECIFIED

SCALE	1:1
AREA mm <sup>2</sup>	589.462
PERIMETER mm.	302.991
WEIGHT kg/m	1.592

PARTY'S NAME SP FABRICATORS PVT. LTD., NAVI MUMBAI

PARTY'S DRAWING No. AL-631

ALLOY & TEMPER 6063 T6

DESCRIPTION TRANSOM PROFILE

DRAWING No.	SECTION No.
P-9556	-
S2330	S2330
35549	35549