

P-10021

S2547

35560

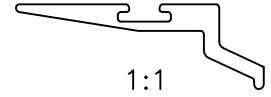

1:1

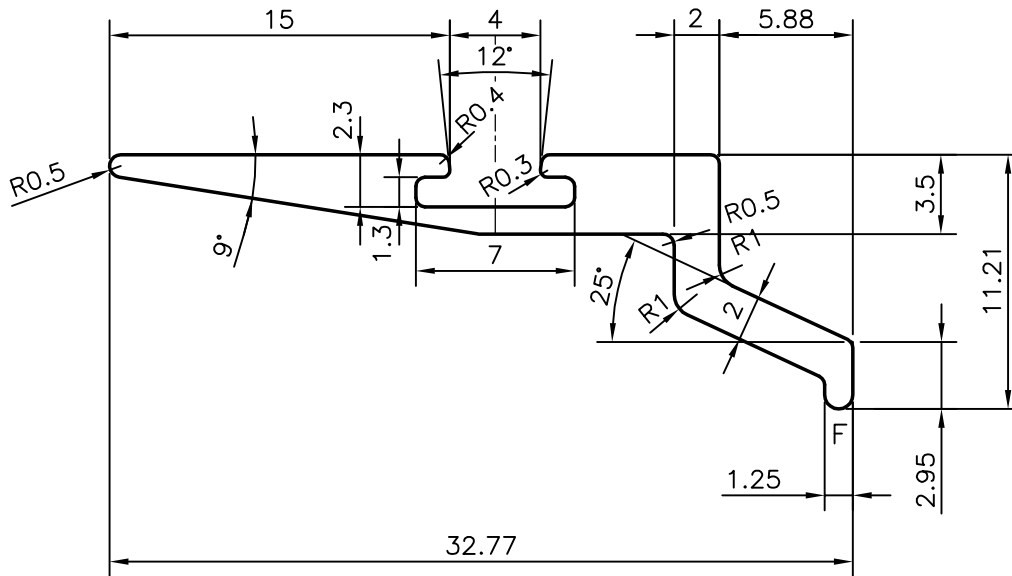

F= FULL RADIUS



SYMBOL OF QUALITY
AN ISO 9001 COMPANY

JINDAL ALUMINIUM LTD.
BANGALORE-560073 (INDIA)

	NAME	DATE
DRAWN	J.P.KAUSHIK	14-05-2010
CHECKED		
APPROVED	S.S.GARG	03-06-2010
SCALE		3:1
AREA mm ²		81.659
PERIMETER mm.		88.625
WEIGHT kg/m		0.220

1. ALL DIMENSIONS ARE IN mm.
2. ROUND OFF ALL SHARP CORNERS WITH 0.40 mm.
3. TOLERANCES WILL BE AS PER IS:3965-1981 UNLESS OTHERWISE SPECIFIED

PARTY'S NAME	ALUPLEX INDIA PVT. LTD., HYDERABAD
PARTY'S DRAWING No.	AP-1099
ALLOY & TEMPER	6063 T6
DESCRIPTION	MISC. SECTION

DRAWING No.	SECTION No.
P-10021	-
S2547	S2547
35560	35560